



**FIELDMANN**<sup>®</sup>  
Home & Garden Performance

**20V** Li-ION  
**FASTPOWER**



FZR 70335-A

---

English .....	7-28
Čeština.....	29-50
Slovenčina .....	51-72
Magyarul .....	73-94
Polski .....	95-116

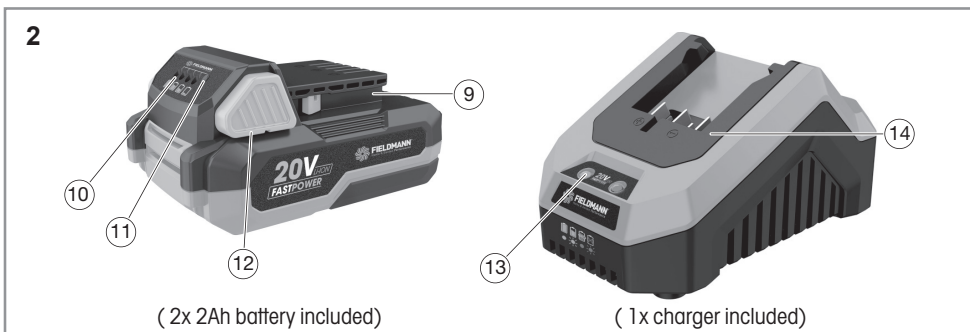

3

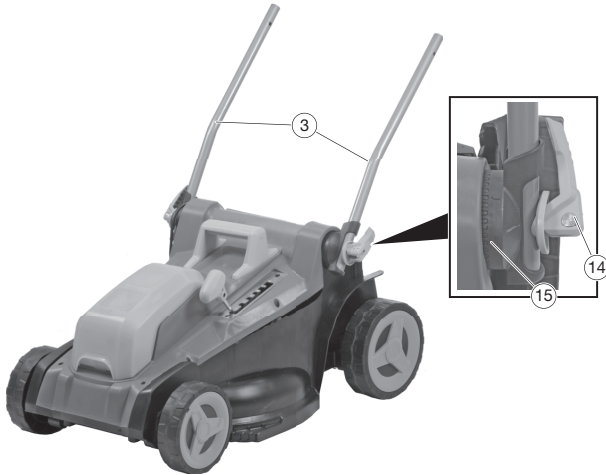

4



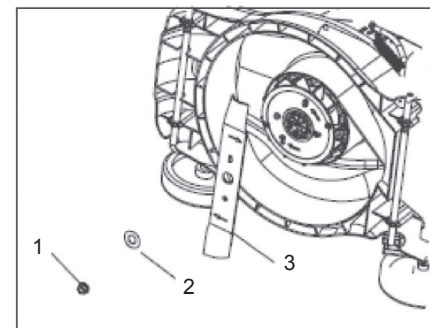
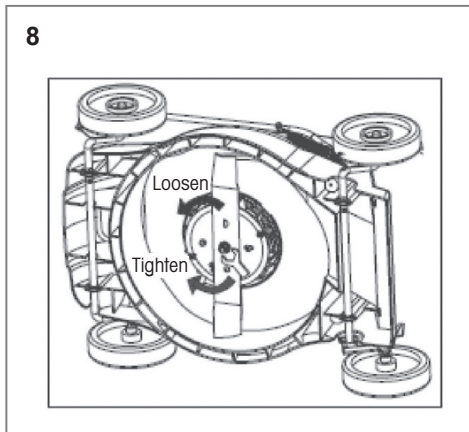
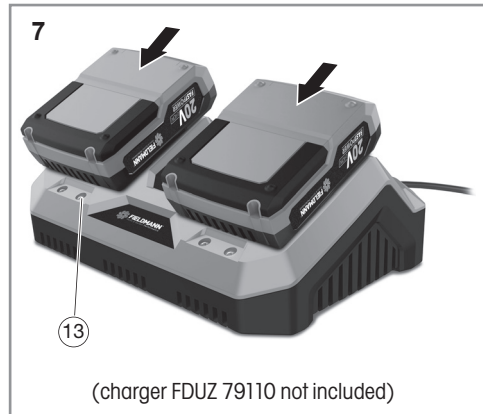
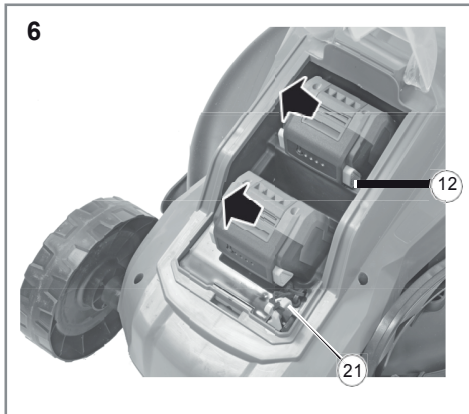
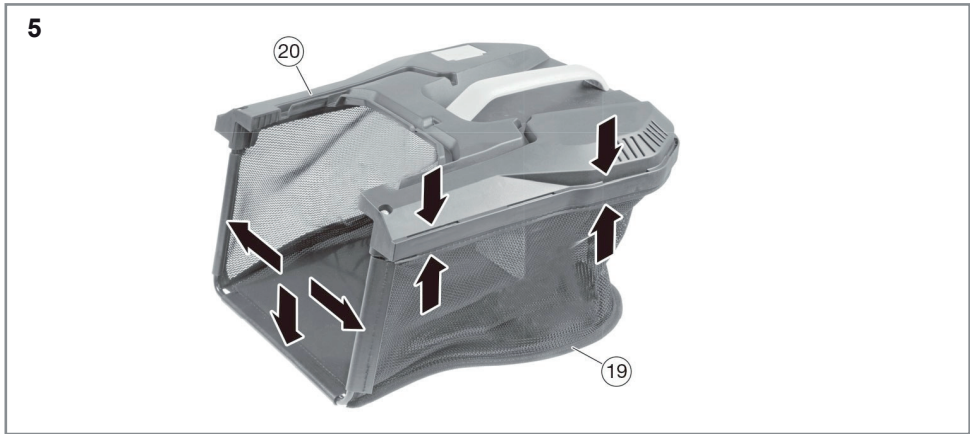

## Quick charger



## Battery 2 Ah

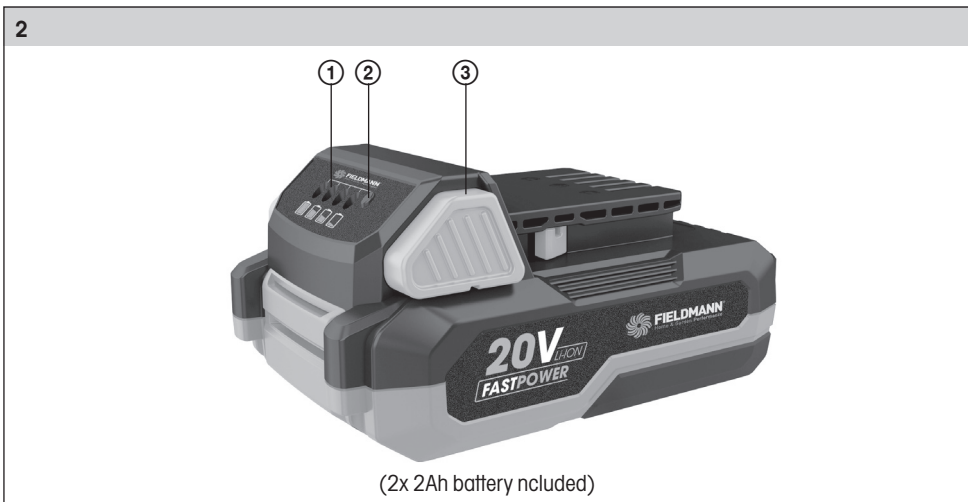

# Cordless lawn mower 330mm

## USER'S MANUAL

**Thank you for purchasing this cordless lawn mower with battery and charger. Before you start using it, please carefully read this user's manual and save it for possible future use.**

### Section: Cordless lawn mower

1. GENERAL SAFETY REGULATIONS .....	8
2. SYMBOLS .....	9
3. DESCRIPTION.....	10
4. BASIC WORK SAFETY .....	12
5. ASSEMBLY .....	14
6. OPERATION.....	16
7. TECHNICAL SPECIFICATIONS.....	17
8. TROUBLESHOOTING.....	18
9. MAINTENANCE.....	19
10. DISPOSAL .....	20

### Section: Quick charger

1. Intended use .....	21
2. General safety instructions .....	21
3. Battery tool use and care.....	21
4. SYMBOLS AND PICTOGRAMS.....	22
5. Charging the battery pack.....	23
6. Disposal .....	24
7. Technical data .....	24

### Section: Battery 2 Ah

1. SYMBOLS .....	25
2. SAFETY INSTRUCTIONS FOR THE BATTERY PACK AND BATTERY SAFETY.....	26
3. DISPOSAL .....	27
DECLARATION OF CONFORMITY .....	28

# 1. GENERAL SAFETY REGULATIONS

## IMPORTANT SAFETY NOTICE

- ✿ Unpack the product carefully and do not throw away any of the packaging until you have found all the parts of the product.
- ✿ Store the product in a dry place out of reach of children.
- ✿ Read all the warnings and instructions. Failure to comply with the warnings and instructions may lead to electric shock, fire and/or serious injuries.

## PACKAGING

The product's packaging prevents damage during transport. This packaging is a resource and can be recycled.

## USER MANUAL

Before starting to work with the machine, please read the following safety regulations and instructions for use. Get familiar with the controls and correct use of the equipment. Keep the user's manual in a safe place for easy future reference. Save the original packaging, including the internal packing material, guarantee card and proof of purchase receipt for at least the time of the guarantee. If you need to transport this power tool, pack it in the original cardboard box for maximum protection during shipping or transport (e.g. when moving or when you need to send this power tool to a service centre for repair).

 **Note:** If you hand over the appliance to somebody else, do so together with this user's manual. Make sure you use the appliance properly by following the instructions in the included User manual. The user's manual also contains operating, maintenance, and repair instructions.

**The manufacturer assumes no responsibility for accidents or damages arising from failure to comply with these instructions.**

## 2. SYMBOLS



**Risk of injury due to cutting mechanism!**  
**Never reach into the cutting mechanism.**



**Use eye protection.**



**Observe the safety instructions before using the product for the first time.**



**Use ear protection.**



**Keep other persons in distance!**  
**WARNING! When operating the device, take care that no other persons are nearby (safe distance: 5m). This is particularly valid for children and animals.**



**Be careful of the sharp blade edges.**



**Danger of injury!**  
**Beware of hurled-away objects.**  
**Keep bystanders away.**



**Be careful of the sharp blade edges. The blades continue to rotate even after the motor is turned off.**



**Read the Instruction Manual attentively prior to use.**



**Protect the tool from the damp and never expose it to rain!**



**Guaranteed sound power level Lwa 92 dB (A)**



**Before doing any maintenance and repair work disconnect the circuit breaker from the lawn mower.**

## 3. DESCRIPTION

### FIG. 1

1. Switch-on lever
2. Handlebar
3. Handlebar, bottom part
4. Collection box
5. Lever for adjusting the cutting height
6. Battery cover
7. Safety flap
8. Switch-lock

### FIG. 2

9. Battery pack
10. Display for remaining capacity
11. Push button for capacity display
12. Locking button
13. Control lights
14. Battery charger

### SCOPE OF DELIVERY

- Operating manual
- Cordless lawn mower
- Handle
- Collection box
- 2x battery 2 Ah
- Battery charger
- Circuit breaker
- Bag containing small parts

## 4. BASIC WORK SAFETY

### IMPORTANT ACCUMULATOR SAFETY INSTRUCTIONS

- ⚠ Batteries are a chemical source of electrical energy, containing chemical compounds that can cause injury to health, property or the environment. Therefore, handle them with caution.
- ⚠ The battery is ready to supply power at any time, even in undesirable circumstances!
- ⚠ ATTENTION!** even with a partially charged battery, a short circuit may occur and damage it. In the worst case, it may cause an explosion or fire. Therefore, always treat batteries in a way that prevents short circuits (e.g. with paper clips, coins, keys, nails, screws or other small metal objects)!  
Even when stored.
- ⚠ Use only batteries recommended by the device manufacturer.
- ⚠ The battery must not be stored or operated near an open flame. It must also not be thrown into the fire.
- ⚠ Do not dispose of old batteries into regular household waste.
- ⚠ Also, never touch the blades until the machine is disconnected from the power source and until the blades completely stop.
- ⚠ Disconnect the device from the power supply (i.e. remove the battery from the machine):
  - If you need to leave the machine without supervision
  - If you have to leave the machine unsupervised
  - Before every inspection, every cleaning or repairs
  - If you hit a foreign body when working with it
  - If the machine vibrates excessively.
- ⚠ Read carefully the basics of working safely with the machine and the user's manual.
- ⚠ This machine must not be operated by anyone with limited physical, sensory or mental abilities (including children). Furthermore, it must not be used by inexperienced people who do not have the technical knowledge to operate it.

These people must be supervised by a competent person or instructed about the basics of work safety.

- ☼ If children are near the machine, make sure they do not play with it.
- ☼ Tingling or numb hands are indications of excessive vibrations.
  - If this happens, shorten the work cycle, take sufficiently long breaks, share the work among several people or if the lawnmower is used for long periods wear special anti-vibration gloves.
- ☼ An unavoidable consequence of using the lawnmower is the noise when it is running. Therefore, only do noisy work during dedicated hours, or when this type of activity is normal. Respect quiet times and try to limit the work to the shortest possible time.
  - We also recommend that you and persons near the lawnmower wear ear protectors.

## IMPORTANT SAFETY INSTRUCTIONS FOR BATTERY CHARGER

- ⚠ **ATTENTION!** Danger of injury by electric shock!
- ⚠ **ATTENTION!** Check the charger, cable and plug before each use. If damage is found, the charger must not be used.
- ⚠ **ATTENTION!** Before use, read all instructions and warnings on the charger and battery case.
  - ☼ Do not expose the charger to rain, snow or moisture. The entry of water into the battery charger increases the danger of injury by electrical shock.
  - ☼ To reduce the risk of damage to the plug and the power cord, always unplug the power cord by pulling on the plug (never pull the cord).
  - ☼ Make sure that the cable is positioned so that no one is stepping on it, that no one trips over it or is otherwise damaged.
  - ☼ Never charge the battery in an explosive atmosphere and near flammable substances. in a flammable environment. Do not operate on lightly flammable surfaces (e.g. paper, textiles, etc.).
  - ☼ Do not disassemble the charger. If it needs to be replaced or repaired, take it to an authorized service centre. Failure to do so may result in electric shock or fire.
  - ☼ NEVER store or use the charger in places where the temperature may reach or exceed 50° C (such as porches, cars, etc.).
  - ☼ Check that the mains voltage is within the range required by the charger manufacturer. The circuit must be adequately current protected.

## OTHER RISKS

- ⚠ **ATTENTION!** In the event of mechanical damage to the battery compartment, avoid contact with chemicals that may leak from it. In case of contact with chemicals, rinse immediately with clean water. In case of extensive contact or chemical burn or eye contact, seek medical attention as soon as possible.
- ☼ Despite our products being designed to meet the valid technical standards and safety directives, there are still some risks to the user from using the machine:
  - Stones and other fragments may fly out of the mowing deck.
  - If the machine operator does not use ear protectors, then they risk subsequent deafness.
  - Injured fingers during blade maintenance
  - Inhaling grass clipping particles
  - Electric shock from un-insulated parts.

- ✿ This machine must not be operated by those with limited physical, sensory or mental abilities (including children) or inexperienced persons or persons whose technical knowledge is evidently insufficient for the given task; and these people should only operate the device under the supervision of a person that is competent for this task or where the person is thoroughly instructed in working safely with the machine.
- ✿ If children are near the machine, make sure they do not play with it.

**⚠ ATTENTION!** Carefully read the user manual before using this lawn mower. Make sure that you thoroughly know all the control elements. Following the work safety rules for the machine minimises the risk of fire, electric shock or other injuries.

- ✿ Keep the user manual carefully in case it is needed.
- ✿ If the machine is incorrectly operated it could cause an injury. The lawnmower could cause serious injury to the user and those nearby and therefore these work safety rules should always be followed to eliminate this risk if possible.  
The user is responsible for safety when working with the machine. Never use the machine if any of its safety items are missing or not in full working order.

## BEFORE YOU START USING THE LAWN MOWER

- ✿ Carefully read all the instructions provided in this user manual. Thoroughly get to know the machine's control elements and the basics for correct use.
- ✿ Never let children or anyone who you are not certain know the controls and the work safety rules for this machine operate it on their own. The national legislation may also stipulate a minimum age limit for operating this type of machine. Please read the laws governing this area in your country.
- ✿ Never use the lawnmower if people, particularly children or household pets, are moving nearby.
- ✿ Always remember that the user is fully responsible for injuries or damage to property caused by operating this machine.

## PREPARING FOR OPERATION

- ✿ When working with the machine wear suitable footwear and long trousers. Never operate the lawnmower barefooted or in sandals.
- ✿ Before starting work, inspect the ground and remove any items that could be deflected by the machine.

**⚠ ATTENTION!** Before every use of the machine, make sure that the blade, its mounting pin and the lawn mower body in general is not damaged or excessively worn. Always replace a damaged or worn out part, of which there are sets on the machine, with an entire set to prevent imbalance.

## OPERATION

- ✿ Only operate the machine during daylight or sufficient artificial lighting.
- ✿ If possible, do not mow wet grass.
- ✿ Make sure that during work you always have a firm support and a secure stance.
- ✿ Do not run when pushing the mower - walk normally.
- ✿ The following general rules apply for work with the lawn mower: When mowing on a slope, do not move up and down but always along the contours, i.e. horizontally perpendicular to the incline of the slope.

- ✿ Be very careful when changing direction on a slope.
- ✿ Never use the lawn mower on extremely steep slopes.
- ✿ If you need to pull the lawnmower towards you while it is running or if you need to move backwards with the lawnmower, be very careful.
- ✿ Always stop the blades from turning when transporting the machine or moving over an un-grassed area.
- ✿ Never use the machine if any covers are damaged or if any of its safety elements are missing such as deflectors or grass catchers.
- ✿ Always start the motor as described in the user manual, and make sure to keep your feet away from the blades.
- ✿ Never fill the machine when starting the motor unless it is really essential to start it. In this case, turn the side of the lawnmower that is farther away from you upwards.
- ✿ Never put your hands or feet under the lawnmower, in particular near to the moving parts. Never cover the grass ejection chute.
- ✿ Never transport the machine if the motor is still running.
- ✿ Always stop the engine first and remove the battery from the machine; only then can the faults be removed or the grass catcher be emptied.
  - Proceed in the same way before every inspection, cleaning or repair of the machine.
  - If you hit a foreign body make sure the lawnmower has not been damaged, and if it has repair the damage before starting the motor again.
  - Or if the machine starts to vibrate more than unusual (immediately check the machine!)
- ✿ Stop the motor whenever you move away from the machine.

## **MAINTENANCE AND STORAGE**







- ✿ Always make sure that all nuts, pins and bolts are securely tightened so that the machine operates safely.
- ✿ Regularly check the grass catcher for damage or excessive wear and tear.
- ✿ Immediately replace worn out or damaged parts. This will help your lawnmower to operate safely.
- ✿ When setting adjustable elements, take care not to clamp your fingers between the moving blades and the fixed part of the machine. Let the motor cool down before storing the lawnmower in an enclosed area.

## 5. ASSEMBLY





### 5.1 MOUNTING THE HANDLE

 **Note:** All mounting steps must be performed on both sides.

P. 4, item 3



-  Release the clamping lever (15).
-  Fold the bottom part of the handle bar (3) over as shown.
-  Observe the installation direction: Lugs (16) must engage as shown.
-  Press the clamping lever towards the handlebar.
-  If the clamping lever does not safely clamp: open the clamping lever again in a clockwise direction and tighten it to the limit stop.
-  If the clamping lever cannot be tightened to the limit stop: open the clamping lever, make a counter-clockwise revolution, and tighten it to the limit stop.

P. 4, item 4

-  Screw the handle (2) using the carriage bolts (16) and tensioning lever nuts (17) onto the handle under section.
-  Press the clamping lever towards the handlebar.
-  If the clamping lever does not safely clamp: open the clamping lever again in a clockwise direction and tighten it to the limit stop.
-  If the clamping lever cannot be tightened to the limit stop: open the clamping lever, make a counter-clockwise revolution, and tighten it to the limit stop.

### MOUNTING THE COLLECTION BOX

P. 5, item 5

-  Attach the collection bag (19) to the collection basket upper (20).
-  Press the rubber lip as far as possible into the guide!





### 5.2 USING FOR THE FIRST TIME

#### CHARGING THE BATTERY PACK

 **WARNING! Risk of injury!** Comply with all safety instructions when handling rechargeable devices.

 **NOTICE! Risk of damage to the unit!** Do not allow the battery pack to deep discharge.

 **Note:** The Li-Ion battery pack can be charged at any time without affecting the lifetime of the unit. Interrupting the charging process will not damage the battery pack

-  The battery pack must be charged prior to the first start-up (charging time: Technical data – p. 17).
-  Press in the locking button (12) and remove the battery from the device.
-  Insert the battery pack into the charger.
-  Plug the charger into the power supply.

The charging status is displayed by the control lights (13).

-  Slot the battery pack into the device and make sure it clicks into place correctly.

## CHECKING THE REMAINING CAPACITY OF THE BATTERY

- ✿ Press the button (11).

The remaining capacity of the battery is displayed by the control lights (9).

## PREPARATION

Set the cutting height

The cutting height can be set to several different heights (Cutting heights: Technical data – p. 17).

P. 3, item 1

- ✿ Pull the lever (5) to the side.
- ✿ Set the cutting height to the value you require, and let the lever slot back into place.

Attach the collection box

P. 3, item 1



- ✿ Lift the protective flap (7) and hold.
- ✿ Hook in the collection box (4).
- ✿ Make that the collection box is securely engaged.

## 6. OPERATION

### CHECK BEFORE STARTING!

 **DANGER! Risk of injury!** The product must only be put into operation if no defects are found. Ensure that any defective parts are replaced before the product is used again.

Check the safe condition of the product:

-  Check whether there are any visible defects.
-  Check whether all parts of the product are firmly attached.

### Turning on the tool

 **Note:** The product cannot be switched on without the circuit breaker.

### Switching-off the device

-  Release the switch on lever.

### Mowing

 **WARNING! Risk of injury!** Before starting work, check the area and remove all objects which may be kicked up by the unit.

-  Guide the unit at an even, slow pace (walking speed) and with as straight a path as possible.

### Important notes

- Always work at right angles to the slope.
- Try not to cut grass when wet.
- Use overlapping paths to produce an even cutting pattern.
- Cut longer grass with a greater cutting height initially, then cut crosswise using the desired cutting height.

P. 6, item 9

- If the air flap (22) closes, the collection container is full and must be emptied.

## 7. TECHNICAL SPECIFICATIONS

Model	FZR 70335-A
Power source	2 x 20 V / 2 Ah (included)
Charging time	1 hour / 1 pc of 2 Ah
Idling speed	3900 RPM
Cutting width (blade length)	330 mm
Mowing heights	25 – 65 mm (5 positions)
Grass catcher volume	35 l
Recommended mowing area:	up to 350 m <sup>2</sup>

### ACCESSORIES

Item number	Accessory
FDUZ 79020	Battery pack 2 Ah (in package 2 pcs included)
FDUZ 79040	Battery pack 4 Ah
FDUZ 79100	Fast charger (in package 1 pc included)
FDUZ 79110	Fast dual charger

## 8. TROUBLESHOOTING

**⚠ DANGER! Risk of injury!** Unprofessional repairs may mean that your unit will no longer operate safely. This endangers you and your environment.

Malfunctions are often caused by minor faults. You can easily remedy most of these yourself. Please consult the following table before contacting the vendor. You will save yourself a lot of trouble and possibly money too.

Error/Fault	Cause	Remedy
Device does not work.	Battery pack discharged?	Charging the battery pack
	Battery pack defective?	Contact your local vendor.
Unit does not switch on.	Did you wait for the delay?	Wait for the switch on delay of 2 seconds.
The mower cuts grass unequally.	The lawn is ragged or bumpy. The mowing height is not set properly.	Check the mowing area. Move the float to a higher position.
Strange noise.	Screws/parts come loose?	Tighten screws.
	Foreign objects in the blades?	Remove foreign objects.
	Blade damaged?	Have blade sharpened, or replace.
Cut result is not sufficient.	Blade is blunt?	Have blade sharpened, or replace.

If you can't fix the fault yourself, contact your nearest vendor. Please be aware that any improper repairs will also invalidate the warranty and additional costs may be incurred.

## 9. MAINTENANCE

**⚠ ATTENTION!** Always switch off the mower and remove the battery before removing the grass catcher.

**📖 Note:** We recommend regularly carrying out the maintenance below, this will increase the lifetime and reliability of the machine.

- ✿ Regularly visually inspect the machine for defects such as a loose blade, blade installed upside down, blade damage or damaged or excessively worn parts.
- ✿ Also regularly check that the protective covers and protective elements are not damaged and are properly placed.
- ✿ Before using the machine, carry out all necessary repairs and maintenance.
- ✿ If, despite regular maintenance, the machine does not work, please contact our customer service, the repair should be carried out by our contractual partner in one of the specialised Fieldmann workshops.

### 9.1 REPLACING THE BLADE

- ✿ For this task, we recommend that you contact an authorised service centre.
- ✿ Always use original spare parts.

**⚠ Important! Always disconnect the mower from the battery and check that the engine is switched off before inspecting the blades.**

**⚠ ATTENTION:** Remember that the blade still rotates several seconds after the motor is turned off. Never attempt to stop the blade. In regular intervals, check that the blade is securely fastened, in good condition and sharp. If necessary, sharpen or replace it.

In the event that the blade hits an object while mowing, turn the lawnmower off and wait until the blade comes to a stop. Then check the condition of the blade and its fastening bolts.

If these are damaged or if they have been lost then they must be replaced without delay.

**⚠ Important! Use protective gloves when working.**

Loosen the bolt holding the blade (using the appropriate wrench) by turning anticlockwise, remove the blade and replace it with a new one. Check that the new blade is installed in the correct direction. Tighten the screw by turning clockwise.

### 9.2 BATTERY CARE

#### Storage after the season

For optimal performance, we recommend that you charge the battery every two months while not in use.

**⚠ ATTENTION:** Fully charge the battery before storing.

**⚠ ATTENTION:** Do not store the battery in places where the temperature drops below 10° C

## 10. DISPOSAL



The machine, rechargeable batteries, accessories and packaging should be sorted for environmentalfriendly recycling.

Do not dispose of power tools and batteries/rechargeable batteries into household waste!

### Only for EC countries:



According to the European Guideline 2012/19/EU, power tools that are no longer usable, and according to the European Guideline 2006/66/EC, defective or used battery packs/batteries, must be collected separately and disposed of in an environmentally correct manner.

### INSTRUCTIONS AND INFORMATION ON DISPOSING OF USED PACKAGING MATERIALS

Put any used package material to the place determined by the municipality for waste disposal.

### DISPOSAL OF USED ELECTRIC AND ELECTRONIC EQUIPMENT



This symbol on products or accompanying documents means that used electric or electronic products must not be put to ordinary municipal waste. Hand over such products to determined collection points for proper disposal, restoration and recycling. Alternatively, in some countries of the European Union or other European countries you can return your products to your local dealer when you buy an equivalent new product. By dutiful disposal of this product you can preserve precious natural resources and you help prevent any potential adverse effects on the environment and human health which could be the results of wrong waste disposal. Ask your local authority or the nearest collection point for additional details. In case of improper disposal of this waste kind penalties can be imposed in accordance with national regulations.

### For companies in the European Union countries

Should you want to dispose of electric and electronic devices, ask your dealer or vendor for necessary information. Disposal in other countries outside the European Union. Should you want to dispose of this product, ask your local authorities or your dealer for necessary information about disposal method.



This product fulfils all basic requirements of the EU directives that apply to it.

Text, design and technical specifications can change without prior notice and we reserve the right for their change.

User manual in the original language.

# Fast Charger

## 1. INTENDED USE

This product is not intended for commercial use. Generally acknowledged accident prevention regulations and enclosed safety instructions must be observed.

Only perform work described in these instructions for use. Any other use is improper. The manufacturer will not assume responsibility for damage resulting from such use.

## 2. GENERAL SAFETY INSTRUCTIONS

- ✿ To operate this device safely, the user must have read and understood these instructions for use before using the device for the first time.
- ✿ Observe all safety instructions! Failure to do so may cause harm to you and others.
- ✿ Retain all instructions for use, and safety instructions for future reference.
- ✿ If you sell or pass the device on, you must also hand over these operating instructions.

## 3. BATTERY TOOL USE AND CARE

- ✿ Recharge only with the charger specified by the manufacturer. A charger that is suitable for one type of battery pack may create a risk of fire when used with another battery pack.
- ✿ Use power tools only with specifically designated battery packs. Use of any other battery packs may create a risk of injury and fire.
- ✿ When battery pack is not in use, keep it away from other metal objects, like paper clips, coins, keys, nails, screws or other small metal objects, that can make a connection from one terminal to another. Shorting the battery terminals together may cause burns or a fire.
- ✿ Under abusive conditions, liquid may be ejected from the battery; avoid contact. If contact accidentally occurs, flush with water. If liquid contacts eyes, additionally seek medical help. Liquid ejected from the battery may cause irritation or burns.

### **Additional safety notes**

- ✿ Do not open the battery. The battery may be damaged as a result of improper actions.
- ✿ Do not expose the battery to heat, fire, water and damp. There is a risk of explosion.
- ✿ In the event of damage or incorrect use of the battery, vapours may escape. Make sure that the ventilation is good and, if you have any medical complaints, consult a doctor. These vapours may irritate the air passages and cause illness.
- ✿ Never attempt to recharge batteries that are not designated rechargeable. There is a risk of fire and explosion.
- ✿ The battery may only be used in conjunction with this power tool. Other power tools may overload the battery and thus damage it.

- ✿ Only batteries authorised by the manufacturer with the values listed on the type plate of this power tool may be used. The use of a different battery may cause a risk of injuries and property damage as a result of an exploding battery.
- ✿ Only chargers authorised by the manufacturer with the values listed on the type plate of this battery may be used. The use of a different charger may cause a risk of injuries and property damage as a result of an exploding battery.
- ✿ Symbols affixed to your unit may not be removed or covered. Information on the unit that is no longer legible must be replaced immediately.

## 4. SYMBOLS AND PICTOGRAMS



Before putting the unit into operation, read and observe the instructions for use.



Only re-charge the battery pack indoors.



Do not dispose of a battery pack with the household waste!



Do not dispose of a battery pack in water!



Do not burn the battery pack!

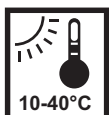

Do not expose the battery pack to sunlight or increased temperatures!

## 5. CHARGING THE BATTERY PACK



**Note:** The rechargeable battery is not included and is available as an option.



**Note:** The actual appearance of your product may differ from the illustrations.

### **⚠ WARNING!**

**Risk of injury! Comply with all safety instructions when handling rechargeable devices.**

### **⚠ NOTICE!**

**Risk of damage to the unit! Do not allow the battery pack to deep discharge.**



**Note:** If the battery is fully loaded, the charger automatically switches over to the maintenance charge function. The battery can thus remain in the charger permanently.

- ✿ The battery pack must be charged prior to the first start-up.
- Press in the locking button (3) and remove the battery from the device.
- Insert the battery pack into the charger.
- Plug the charger into the power supply.

The charging status is displayed by the control lights (4).

- Slot the battery pack into the device and make sure it clicks into place correctly.

### **Control lights (4)**

- ✿ **Green light flashing** - charging
- ✿ **Green light shine** - fully charged battery
- ✿ **Red light flashing** - problem with battery, please carefully check proper insertion of the battery into the charger. If the problem will continue, please contact the nearest service point
- ✿ **Red light shine** - high temperature of battery, please wait at least 60 mins and try again

### **Checking the remaining capacity of the battery**

- Press the button (2).

The remaining capacity of the battery is displayed by the control lights (1).

## 6. DISPOSAL

### INSTRUCTIONS AND INFORMATION ON DISPOSING OF USED PACKAGING MATERIALS

Dispose of used packaging material at a site designated for waste in your municipality.



The appliance and its accessories are manufactured from various materials, e.g. metal and plastic.

Take damaged parts to a recycling centre. Inquire at the relevant government department.

A crossed-out wheeled bin icon means: Batteries and rechargeable batteries, electrical or electronic devices must not be disposed of with household waste. They may contain substances that are harmful to the environment and human health.

Consumers must dispose of waste electrical devices, spent portable batteries and rechargeable batteries separately from household waste at an official collection point to ensure that these items are processed correctly. Information on returning these items is available from the seller. Sellers are required to accept these items free of charge. Batteries and rechargeable batteries, which are not permanently installed in waste electrical devices, must be removed prior to disposal and must be disposed of separately. Lithium batteries and battery packs in all systems must only be returned to a collection point when discharged. Batteries must always be protected against short circuits by covering the poles with adhesive tape.

All end users are responsible for deleting any personal data stored on waste devices prior to their disposal.



This appliance meets all the basic requirements of the EU directives.

Changes in the text, design and technical specifications may be made without prior notice and we reserve the right to make these changes.





User manual in the original language.

## 7. TECHNICAL DATA

Item number	FDUZ 79100 Fast charger
Rated voltage	230 V~, 50 Hz
Rated power	70 W
Charge voltage	20,9 V
Charge current	2,4 A
Protection class	II
Charging time	2 Ah / 60 min, 4 Ah / 120 min

# 2.0 Ah Battery **20V**<sub>Li-ion</sub> **FASTPOWER**

## 1. SYMBOLS

	Do not expose to rain or water
	Do not burn
	Read these operating instructions well before you use the tool
	Risk of injury when instructions are not followed
	The battery can be stored and charged at temperatures between 50°F (10°C) and 104°F(40°C).

### Disposal of the packaging



The packaging consists of cardboard and correspondingly marked plastics that can be recycled. Make these materials available for recycling.

### Disposal of an exhausted battery pack



**Li-ion**

To preserve natural resources, please recycle or dispose of the battery pack properly. This battery pack contains Li-ion batteries. Consult your local waste authority for information regarding available recycling and/or disposal options. Discharge your battery pack by operating your tool, then remove the battery pack from the tool housing and cover the battery pack connections with heavy-duty adhesive tape to prevent short circuit and energy discharge. Do not attempt to open or remove any of the components.

## 2. SAFETY INSTRUCTIONS FOR THE BATTERY PACK AND BATTERY SAFETY

- ✿ Use only the Fieldmann batteries supplied with the Fieldmann Tool or Fieldmann-approved replacements.
- ✿ Do not use the battery to power any device other than the Fieldmann tool it was sold with.
- ✿ Charge the battery only with the Fieldmann charger supplied with the tool or Fieldmann-approved replacements and according to the instructions in the Fieldmann Instruction Manual.
- ✿ Do not charge the battery in a place where static electricity is generated nor let the battery touch something that is statically charged.
- ✿ The battery can be stored at temperatures between 50° F (10° C) and 104°F(40°C).
- ✿ Never store or leave your lithium ion battery in temperatures over that recommended otherwise fire may occur.
- ✿ DO NOT store the Lithium Ion battery anywhere that the temperature can easily reach higher temperatures than recommended -this includes garden type sheds, and Vehicles where the inside temperature can climb to dangerous levels in the direct sunlight and on high temperature days. **THINK BEFORE LEAVING YOUR LITHIUM ION BATTERY PACK IN STORAGE.**
- ✿ **NEVER CHARGE YOU LITHIUM ION BATTERY BELOW OR ABOVE TEMPERATURES RECOMMENDED OTHERWISE FIRE OR SERIOUS DAMAGE TO THE BATTERY PACK MAY OCCUR.**
- ✿ The most suitable temperatures to charge the battery pack are between 68°F(20°C) -77°F (25°C).
- ✿ Always allow the battery pack to cool down after charging, do not place it in a hot environment such as a metal shed or open trailer left in the sun.
- ✿ Take care where the tool is stored. Do not store in areas of corrosive fumes, or salt air or similar conditions. Try and store the tool in the packaging supplied with the tool.
- ✿ Do not dispose of the battery in a fire or put the battery into a microwave oven, conventional oven, dryer, or high-pressure container. Under these conditions, the battery may explode.
- ✿ Never attempt to open the battery pack, puncture the battery or subject the battery to strong physical shock.
- ✿ If the plastic housing of the battery pack breaks open or cracks, immediately discontinue its use and do not recharge it. Ensure the battery pack clip is in good condition and will not allow the pack to fall free from the tool. If the clip is damaged or for any reason is not locking the pack in place, Do Not continue to use.
- ✿ Stop using the battery if it exhibits abnormal heat, odour, colour, deformation, or is in an abnormal condition.
- ✿ If you detect leakage or a foul odour, it is especially important to keep the battery away from fire. If battery liquid leaks onto your skin or clothes, wash well with clean water immediately. If liquid leaking from the battery gets into your eyes, do not rub your eyes. Rinse your eyes well (for at least 10 minutes) with clean water, and consult a doctor immediately.
- ✿ Do not use a leaking battery.
- ✿ Handle batteries with care to avoid shorting the battery with conducting materials, such as nails, screws, metal watch bands, rings, bracelets, and keys. The battery may overheat and could burn you.
- ✿ After the battery has reached the end of its useful life, we recommend recycling the materials at your local municipal council recycling centre. DO NOT attempt to replace the battery cells in the battery pack, repair or modify any part of the battery pack assembly.
- ✿ When recycling, make it nonconductive by applying insulating tape to the terminals located on the battery.

### When to charge the battery

- ✿ New batteries are shipped in a low charged condition and should be fully charged before Use. The battery

pack can be recharged at any time during use, provided the pack is not overheated.

- ☼ If the battery pack starts to cut out due to low voltage, or previous tasks undertaken can no longer be performed, it is suggested to stop using the tool and recharge the battery.
- ☼ For storage, it is suggested to recharge the battery between 50% and 75% charge.

### Checking the remaining capacity of the battery

- ☼ Press the button (2).
- ☼ The remaining capacity of the battery is displayed by the control lights (1).

#### All 4 LEDs are lit:

The battery is fully charged.

#### 3 or 2 on LED(s) are lit:

The battery has an adequate remaining charge.

#### 1 LED blinks:

The battery is empty, recharge the battery.

#### All LEDs blink:

The battery pack is too hot (e.g. due to direct sunshine or prolonged use) or too cold (below 32°F/0°C), Do not use or charge the battery pack, make sure the battery temperature to between 50°F (10°C) and 104°F (40°C).

## 3. DISPOSAL

### INSTRUCTIONS AND INFORMATION ON DISPOSING OF USED PACKAGING MATERIALS

Dispose of used packaging material at a site designated for waste in your municipality.



The appliance and its accessories are manufactured from various materials, e.g. metal and plastic. Take damaged parts to a recycling centre. Inquire at the relevant government department.

A crossed-out wheeled bin icon means: Batteries and rechargeable batteries, electrical or electronic devices must not be disposed of with household waste. They may contain substances that are harmful to the environment and human health.

Consumers must dispose of waste electrical devices, spent portable batteries and rechargeable batteries separately from household waste at an official collection point to ensure that these items are processed correctly. Information on returning these items is available from the seller. Sellers are required to accept these items free of charge. Batteries and rechargeable batteries, which are not permanently installed in waste electrical devices, must be removed prior to disposal and must be disposed of separately. Lithium batteries and battery packs in all systems must only be returned to a collection point when discharged. Batteries must always be protected against short circuits by covering the poles with adhesive tape.

All end users are responsible for deleting any personal data stored on waste devices prior to their disposal.



This appliance meets all the basic requirements of the EU directives.

Changes in the text, design and technical specifications may be made without prior notice and we reserve the right to make these changes.

User manual in the original language.

# DECLARATION OF CONFORMITY

# FAST<sup>®</sup>

FAST ČR, a.s.  
Černokostecká 1621, 251 01 Říčany, Czech Republic  
tel.: +420 323 204 111, fax: +420 323 204 110

## EU DECLARATION OF CONFORMITY

**Product / brand:** Cordless Lawn Mower / **FIELDMANN**

**Type / model:** **FZR 70335-A** as factory model D03004500  
DC 2x 20V (battery powered), speed 3900/m<sup>3</sup>, cutting width 330mm,  
Class III, IPX1, L<sub>PA</sub> = 78,9dB(A), L<sub>WA</sub> = 92dB(A)  
FDUZ 79020 as factory model D01102700 (Lion battery)  
DC 20V, 2000mAh, 40Wh  
FDUZ 79100 as factory model D02103000 (charger)  
Input AC 200-240V, 50/60Hz, 70W, Class II  
Output DC 20V, 2,4A

**Manufacturer:** FAST ČR, a.s.  
Černokostecká 2111, 100 00 Praha 10, Czech Republic  
VAT no: CZ26726548

**The product is inline with directives and regulations listed below:**

Directive MD 2006/42/EC  
Directive EMC 2014/30/EU  
Directive NEE 2000/14/EC  
Directive RoHS 2011/65/EU

**and norms:**

EN 60335-1:2012+A11+A13  
EN 60335-2-77:2010  
EN 62233:2008  
EN 55014-1:2017  
EN 55014-2:2015



**Place of issuance:** Prague

**Name:** Ing. Zdeněk Pech  
Chairman of the Board

**Date of issuance:** 22. 7. 2020

**Signature:**

**FAST<sup>®</sup>** FAST ČR, a.s.  
Černokostecká 1621, 251 01 Říčany  
IČO: 26726548 tel.: +420/ 323 204 111  
DIČ: CZ26726548 fax: +420/ 323 204 110

IČO: 26 72 65 48. DIČ: CZ-26 72 65 48

**Bankovní spojení:** Komerční banka Praha 1, č.ú. 89309011/0100, Česká spořitelna Praha 4, č.ú. 2375682/0800,  
ČSOB Praha 1, č.ú. 8010-0116233383/0300