



Strip Down Information

54V XR FLEX VOLT SDS-Max Hammer



BRUSHLESS

54V
LITHIUM ION

TRUE CORDED POWER



D25481K
AC Combi



D25810K
AC Chipper



BRUSHLESS

54V
LITHIUM ION

DCH481X2
DC Combi

Brushless Motor (DC Only)

Fastest drilling speed at 28mm

**Low Vibration
8.5m/s²**

6.0J = corded performance

**9.0Ah battery pack
(167Wh)**

Rotary Only



**PERFORM
PROTECT**

**54V
LITHIUM ION**

Brand	CAT No	Voltage	Impact Energy	Weight	Vibration
DEWALT	DCH481X2	54V	6.0J	6.5Kg	8.5m/s ²
DEWALT	D25481K	AC	6.0J	5.5Kg	8.5m/s ²

Before repair and service

Follow the
safety instruction

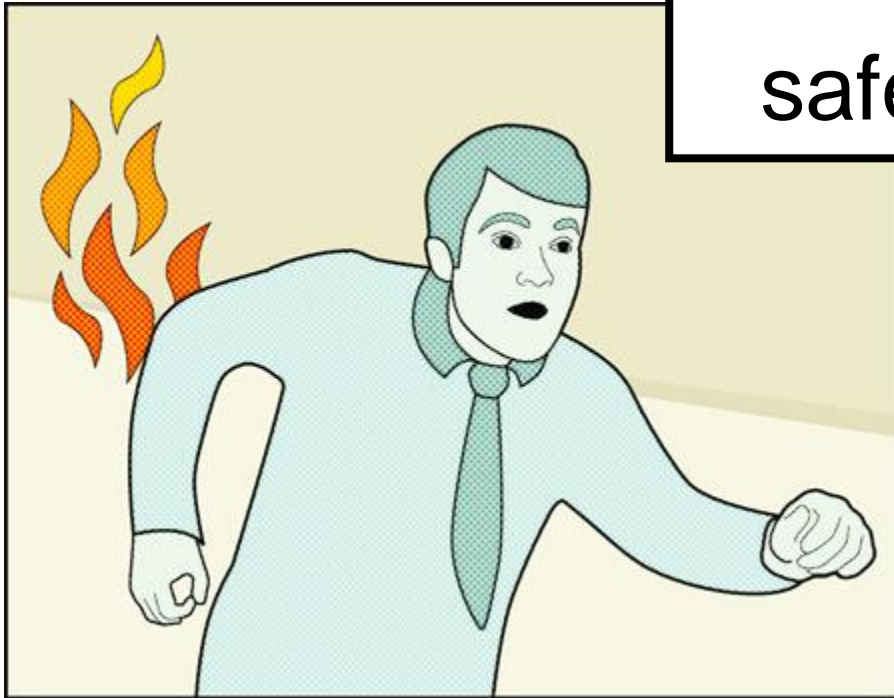



Safety Notes

Before attempting any repairs, the following should be observed,

Ensure that the correct tool is used and only use good quality hand tools

Ensure the work shop is clean and tidy.

Always wear protective clothing, Overalls, safety gloves, safety glasses, safety hat/net etc.

Before turning product on for analysis carry out a visual check for loose/broken parts including accessories, drill bits, chisels, cutters etc.

Never repair a product whilst it is into a power supply, or a battery is connected.

Remove accessories, drill bits, chisels, cutters etc.

Ensure side handles function correctly.

After repair

Run product to check that it functions correctly, including all features.

Before repair and strip down

Carry out an visually check like:

Condition of contacts (unit charger and battery)

mode selector

leakages

condition of tool holder

Before repair and strip down

Carry out an functionality check like:

hammer mechanism

modes

reverse mode

measure the unload current

measure the capacity of batteries

check condition of charger (use the charger to charge a obviously good battery and measure the capacity of the battery)

Legend of Icons

	ENGLISH	GERMAN	ITALIAN	FRENCH	SPANISH	PORTUGUESE	DUTCH
	CHECK	ÜBERPRÜFEN	CONTROLLARE	CONTROLLER	COMPROBAR	VERIFIQUE	CONTROLEREN
	CUT / REMOVE	Entfernen / TRENNEN	TAGLIARE/RIMUOVERE	Couper / Enlever	Cortar/ quitar	Cortar / Remover	SNIJ / VERWIJDER
	SWITCH ON	ANSCHALTEN	ACCENDERE	ALLUMEZ	ENCENDER	LIGAR	AANSCHAKELEN
	TURN CLOCKWISE	DREHEN IN UHRZEIGERSINN	GIRARE IN SENSO ORARIO	TOURNEZ DANS LE SENS DES AIGUILLES D'UNE MONTRE	GIRO DERECHA	GIRAR NO SENTIDO HORARIO	DRAAI RECHTSOM
	MOVE IN THIS DIRECTION	IN RICHTUNG BEWEGEN	MUOVI IN DIREZIONE	BOUGEZ DANS CETTE DIRECTION	DIRECION DE LA FLECHA	AVANÇAR NESSA DIREÇÃO	BEWEEG IN DE RICHTING VAN DE PIJL
	CORRECT	RICHTIG	CORRETTO	CORRECT	CORRECTO	CORRECTO	GOED
	FUNCTION TEST	FUNKTIONSTEST DURCHFÜHREN	ESEGUIRE IL TEST	TEST FONCTIONNEL	PRUEVA DE FUNCIONAMIENTO	TESTE DE FUNCIONAMENTO	FUNCTIETEST
	LIFT OVER	ANHEBEN	SOLLEVARE	SOULEVEZ	LEVANTAR	LEVANTAR SOBRE A	OPHEFFEN
	DATE CODE	HERSTELLUNGS- DATUM	DATA DI PRODUZIONE	DATE CODE	FECHA FABRICACION	CÓDIGO DE PRODUÇÃO	DATUM CODE

Legend of Icons

	ENGLISH	GERMAN	ITALIAN	FRENCH	SPANISH	PORTUGUESE	DUTCH
	SEQUENCE	REIHENFOLGE	SEQUENZA	SEQUENCE	SECUENCIA	SEQUÊNCIA	VOLGORDE
	DISCONNECT	TRENNEN	SCOLLEGARE	DEBRANCHEZ	DESCONECTADO	DESLIGAR	ONTKOPPELEN
	SERVICE TOOL	SERVICE WERKZEUG	UTENSILE DI SERVIZIO	OUTILLAGE DE SERVICE	HERRAMIENTAS DE SERVICIO	FERRAMENTAS DE SERVIÇO	SERVICE GEREEDSCHAP
	LISTEN	HÖREN	ASCOLTARE	ECOUTEZ	ESCUCHAR	OUVIR	LUISTEREN
	HOW DOES IT WORK?	WIE FUNKTIONIERT DAS?	COME FUNZIONA?	COMMENT CELA FONCTIONNE?	¿ COMO FUNCIONA?	COMO FUNCIONA?	HOE WERKT DIT?

Legend of Icons

	ENGLISH	GERMAN	ITALIAN	FRENCH	SPANISH	PORTUGUESE	DUTCH
	USE STATIC PROTECTION DEVICE	ANTISTATIK MATTE BENUTZEN	USARE I DISPOSITIVI ANTISTATICI	UTILISEZ UN EQUIPEMENT DE PROTECTION ANTISTATIQUE	USE PROTECCION ANTIESTATICA	USE PROTEÇÃO ESTATICA	GEBRUIK ANTI-STATISCH MATERIAAL
	TORX HEAD SCREWDRIVER	TORX-SCHRAUBEN-DREHER	CACCIAVITE TORX	TOURNEVIS TORX	DESTORNILLADOR TORX	CHAVE TORX	TORX SCHROEVENDRAAIER
	FLAT SCREWDRIVER	SCHLITZ-SCHRAUBEN-DREHER	CACCIAVITE PIATTO	TOURNEVIS PLAT	DESTORNILLADOR PLANO	CHAVE DE FENDA	PLATTE SCHROEVENDRAAIER
	USE A PRESS	EINE PRESSE VERWENDEN	USARE LA PRESSA	UTILISEZ UNE PRESSE HYDRAULIQUE	USE PRENSA	USE UMA PRENSA	GEBRUIK EEN WERKPLAATSPERS
	TURN COUNTER CLOCKWISE	DREHEN GEGEN UHRZEIGERSINN	GIRARE IN SENSO ANTIORARIO	TOURNEZ DANS LE SENS INVERSE DES AIGUILLES D'UNE MONTRE	GIRO IZQUIERDA	GIRAR SENTIDO ANTI-HORARIO	DRAAI LINKSOM

Visually check

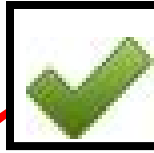

Visually check

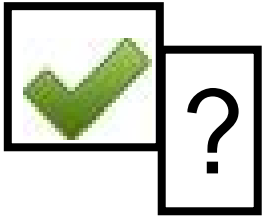

Visually check

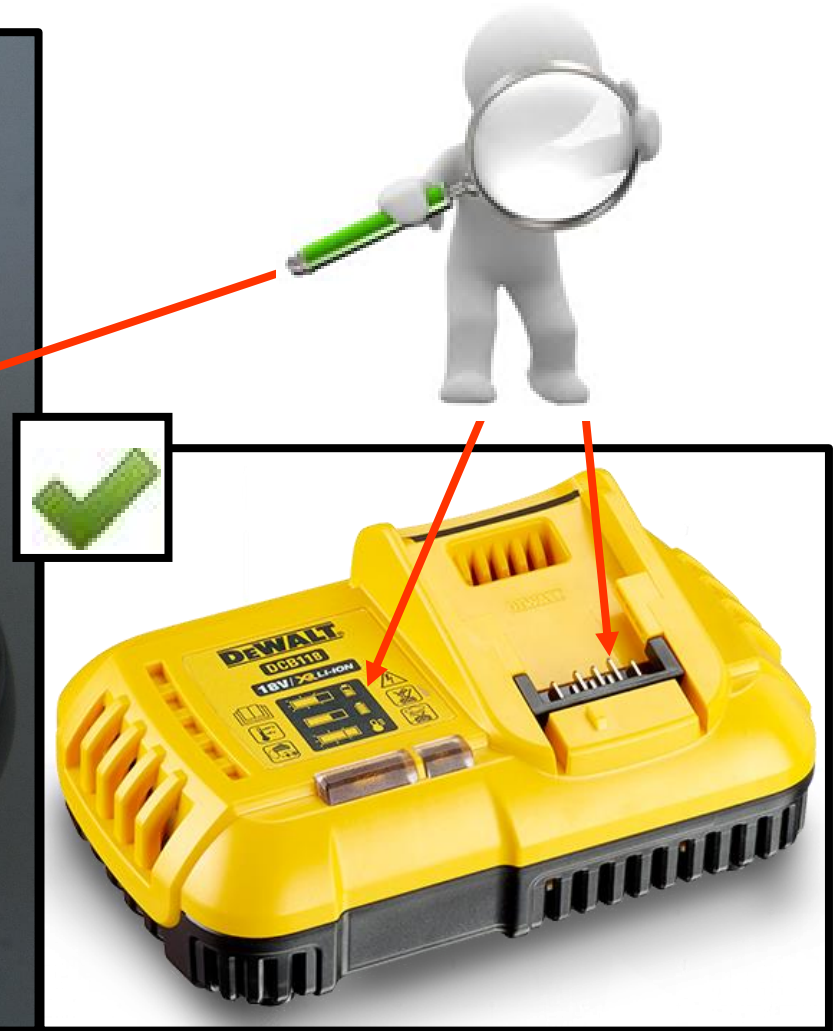

Functionally check

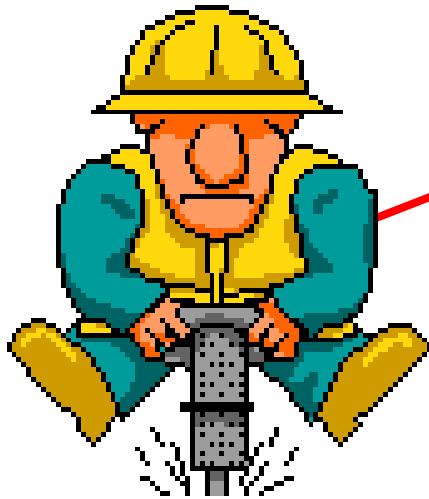

Disassembling Front Housing

Disassembling



Disassembling tool holder



Disassembling tool holder



Disassembling tool holder



Disassembling tool holder

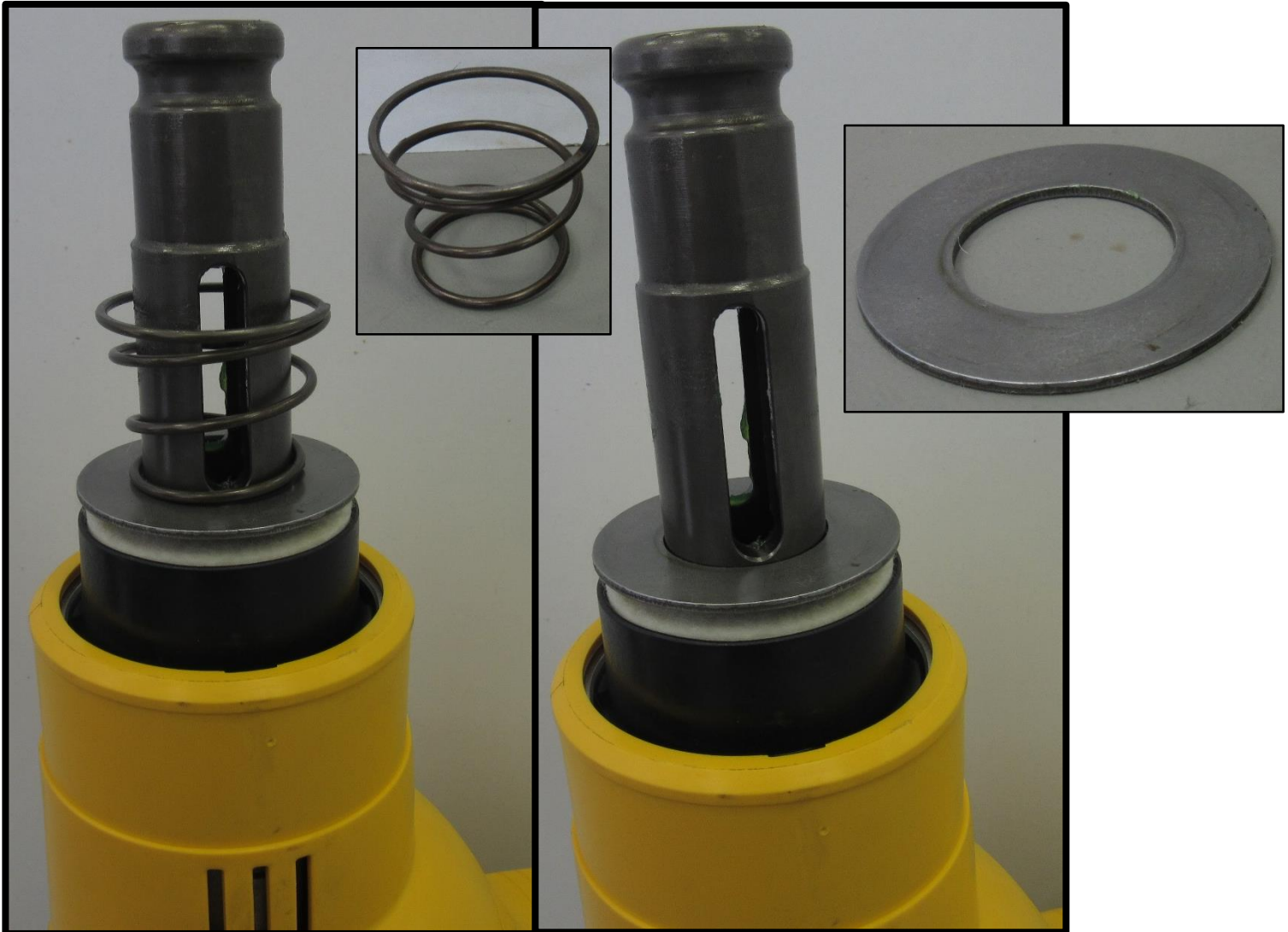

Disassembling spindle

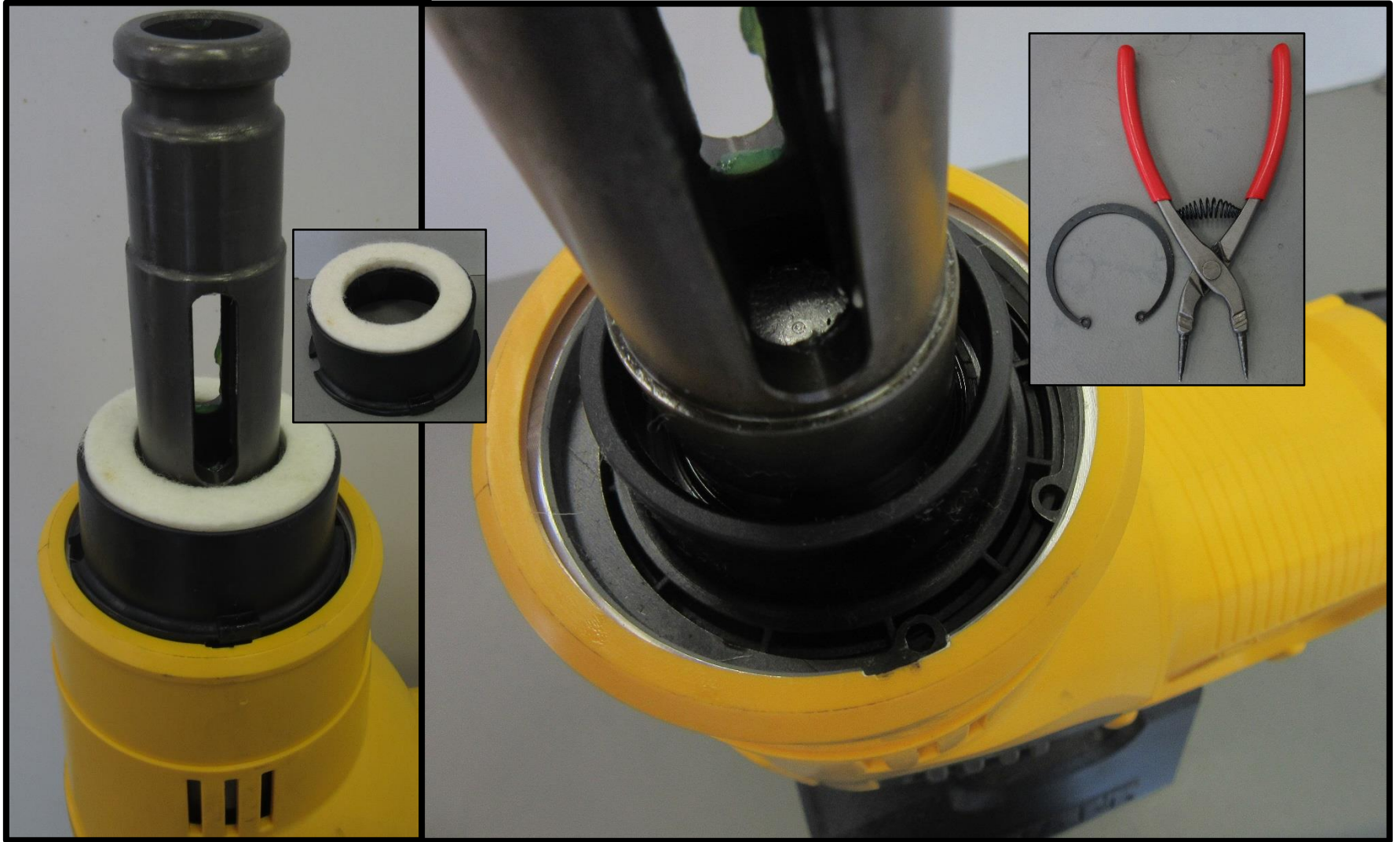

Disassembling tool holder

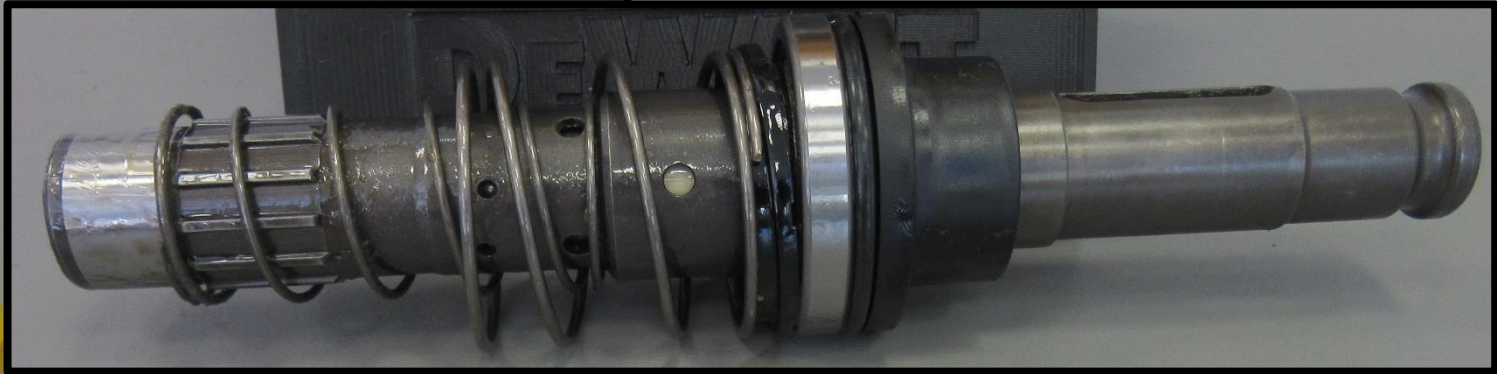

Disassembling spindle

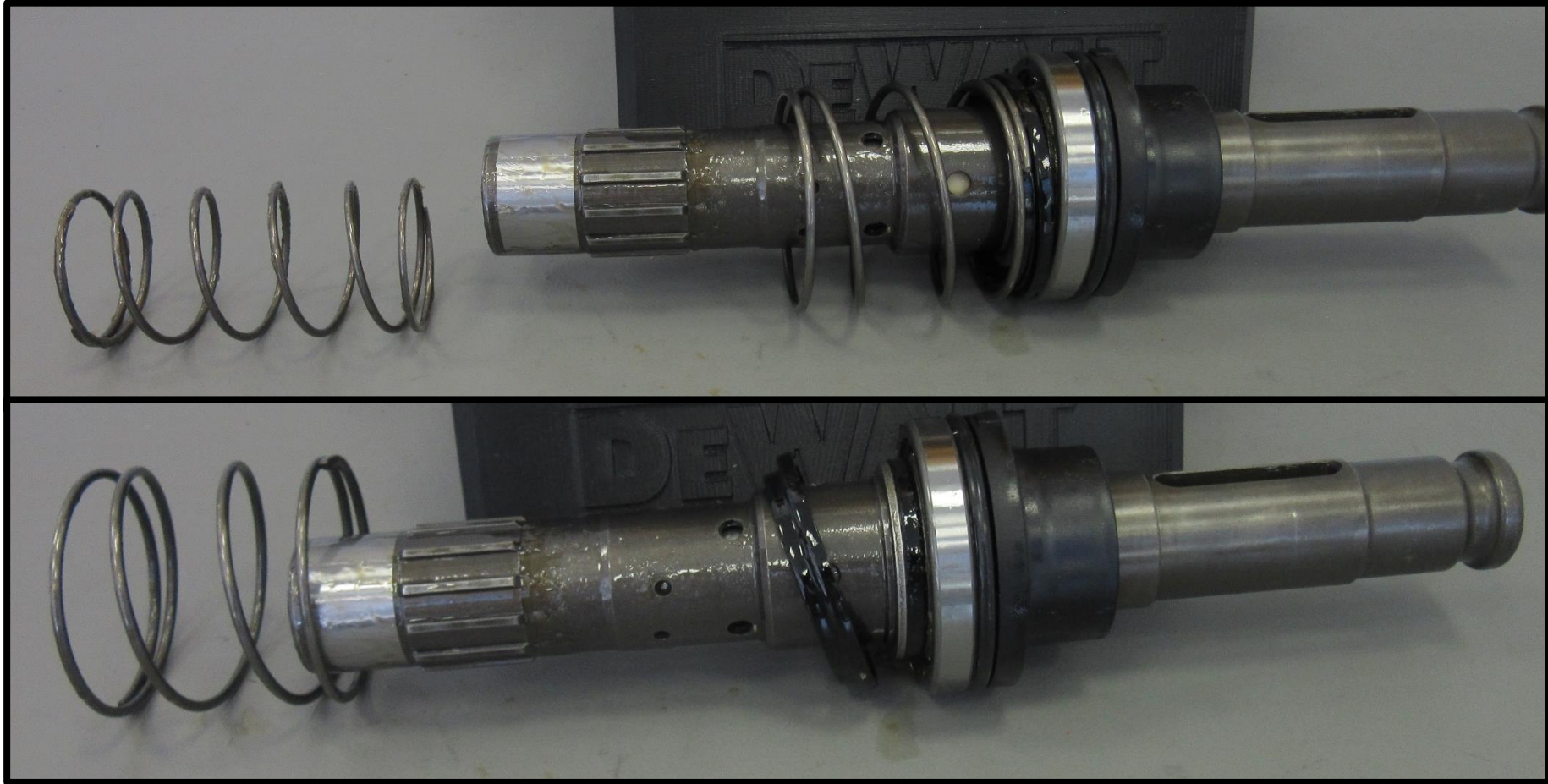

Disassembling spindle

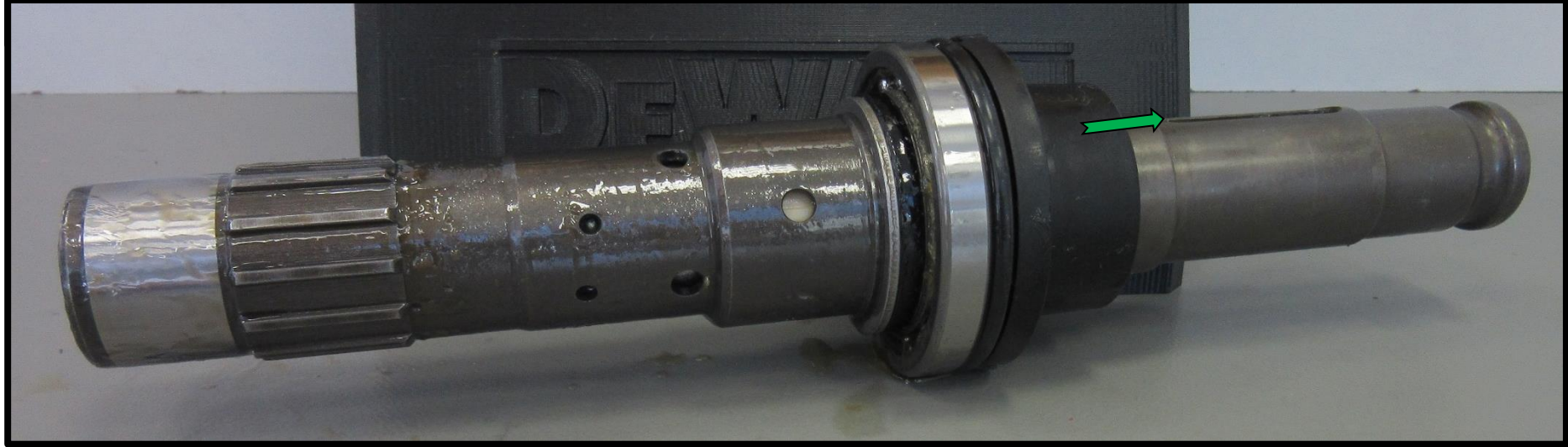
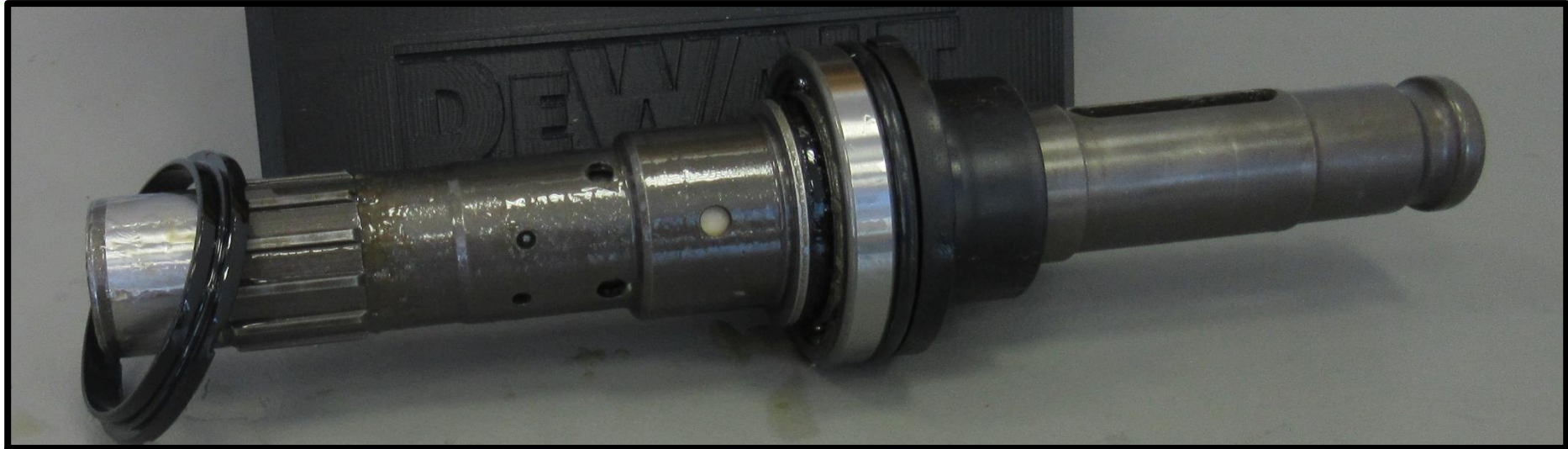

Disassembling spindle

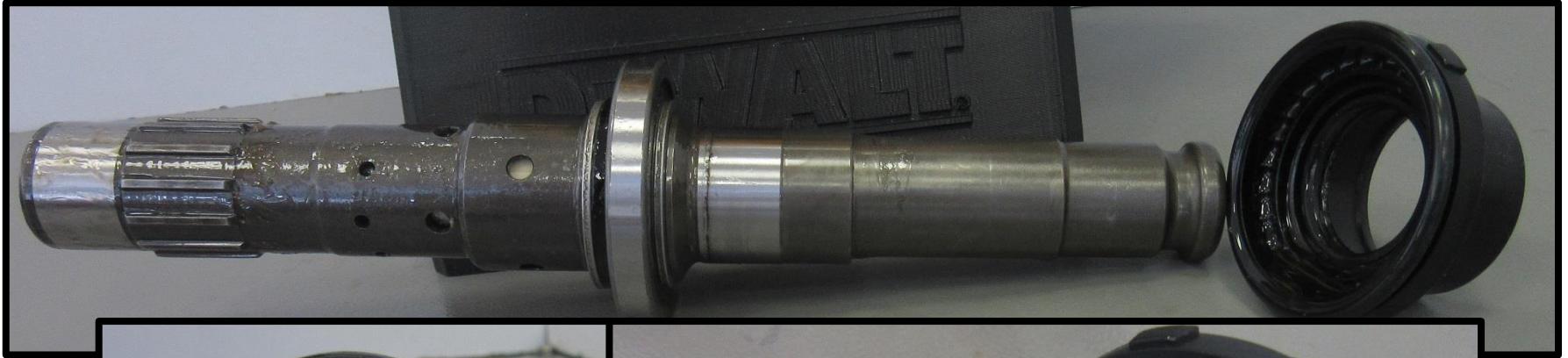

Disassembling spindle

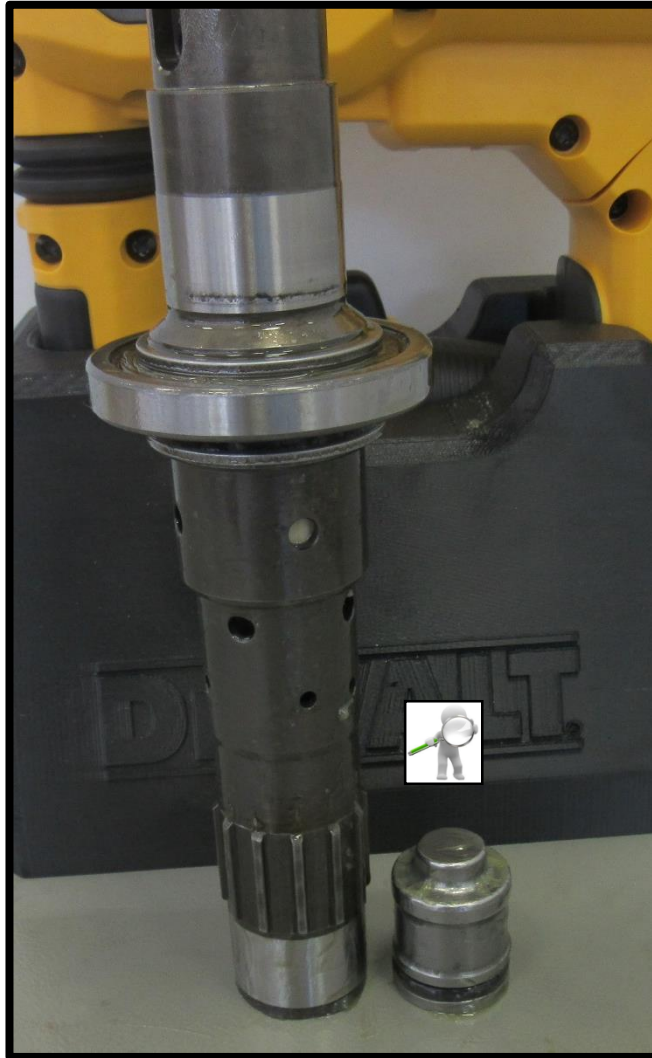

Disassembling spindle / gear components

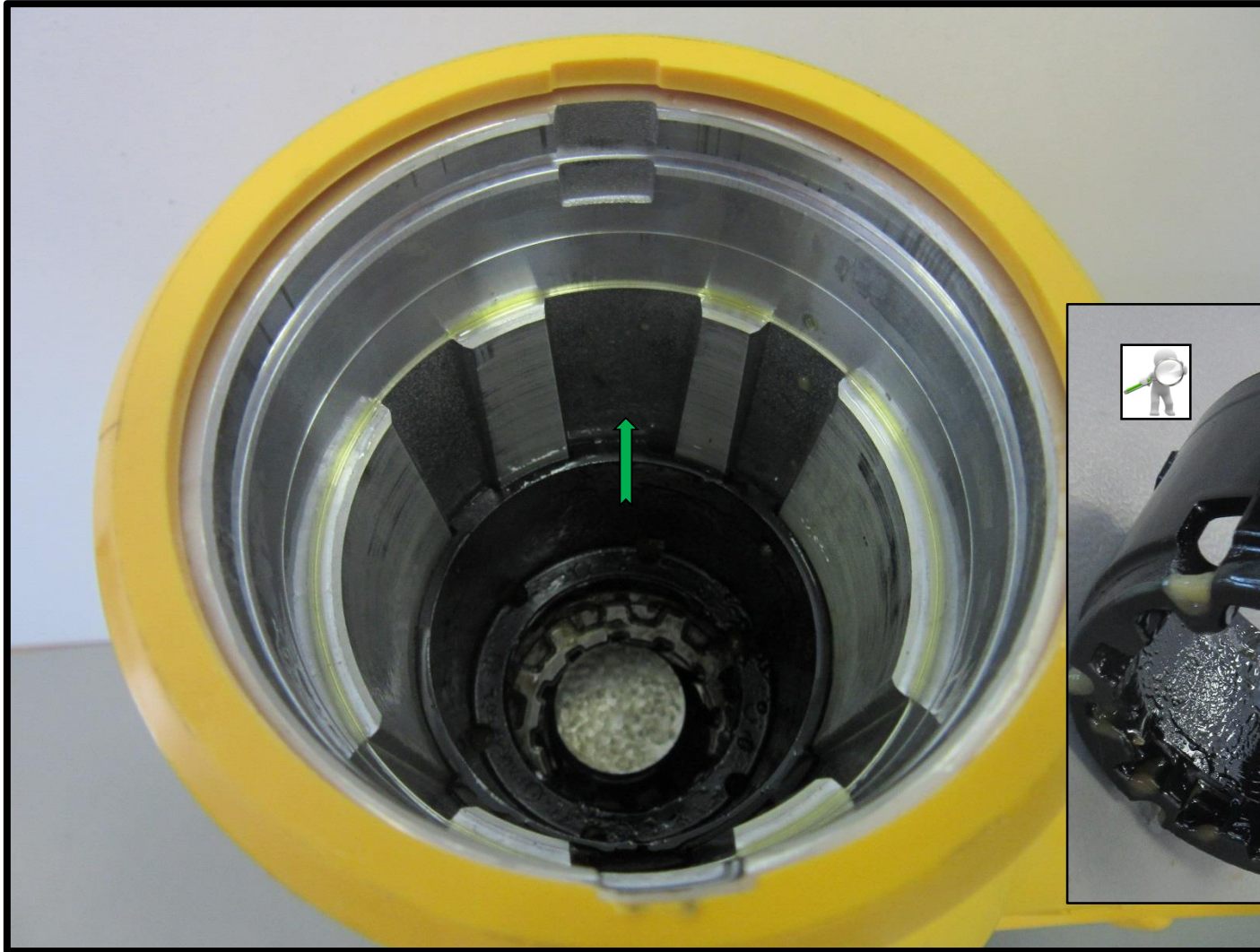

Disassembling spindle / gear components

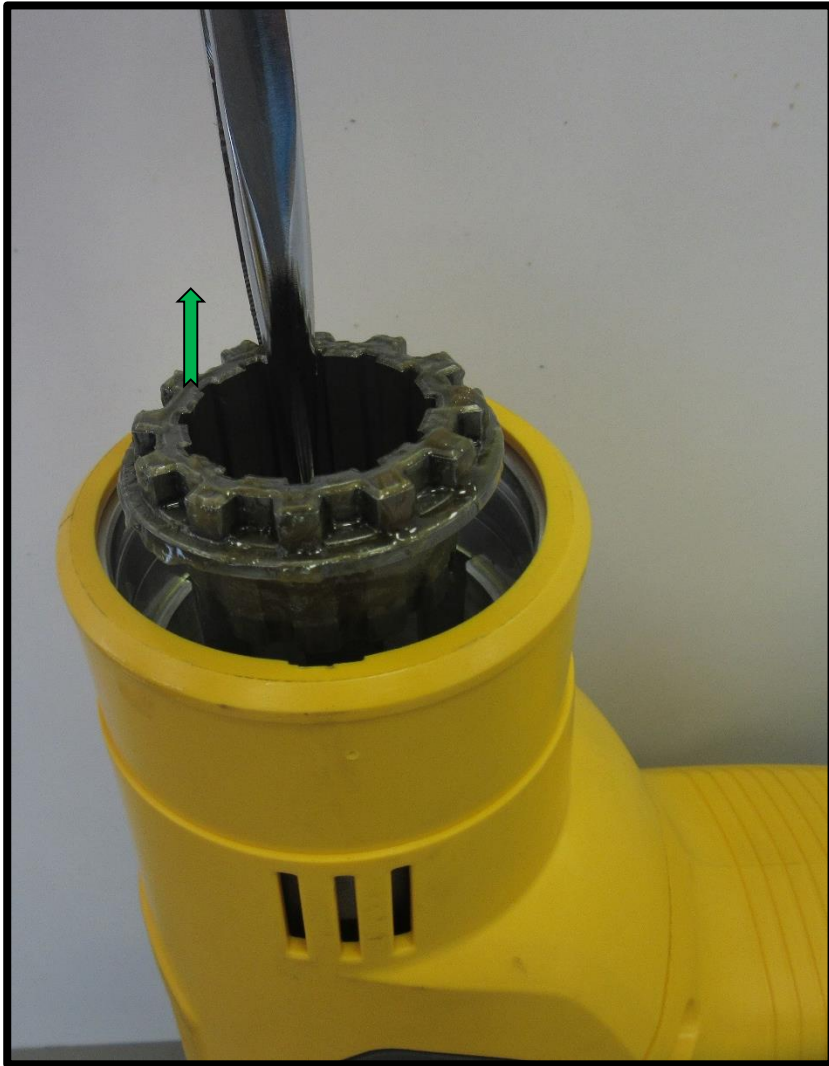

SERVICE TOOLING PART 1003961-99

THIS
SIDE
FOR
COMBI
UNITS
DCH481
AND
D25481



THIS
SIDE
FOR
CHIPPER
UNITS
D25810
AND
D25811

TOP TOOLING TO REMOVE TOP HALF OF SPINDLE

SERVICE TOOLING PART 1003962-99
FOR SDS MAX UNITS



SERVICE TOOLING PART 1003963-99
FOR 17MM HEX UNITS (NOT EUROPE)



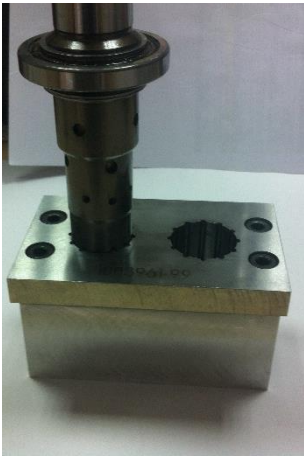



Release torque up to 200Nm

USE IMPACT WRENCH
DCF899 OR SIMILAR

Disassembling spindle / hammer mechanism

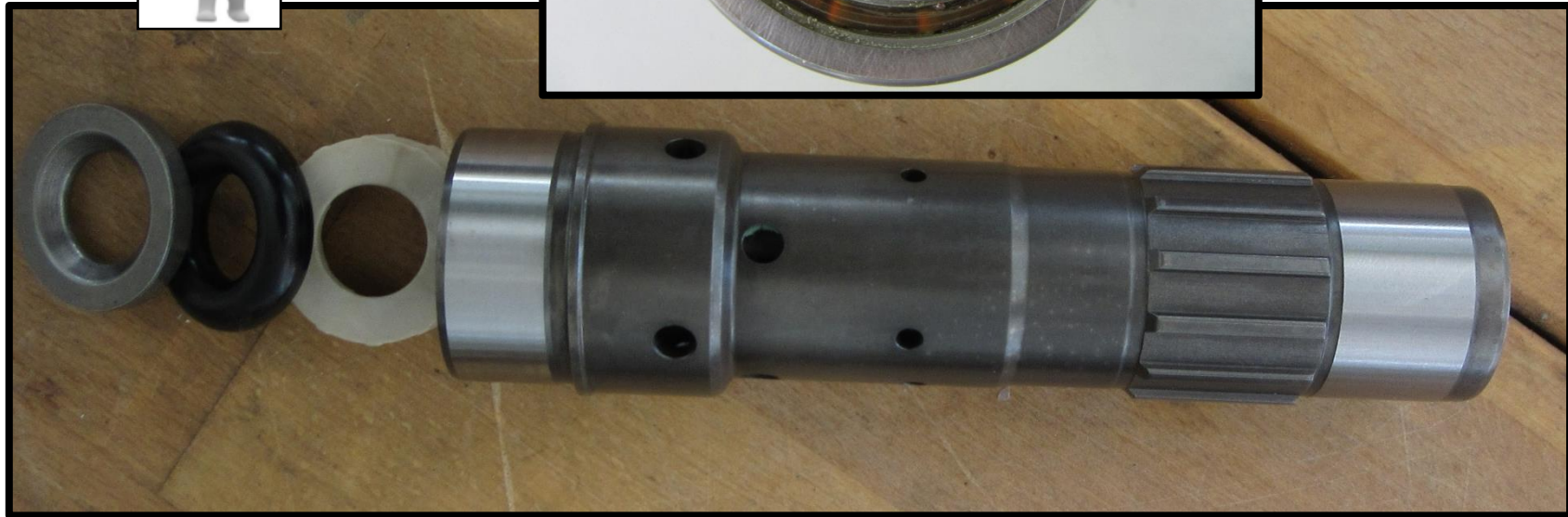

Disassembling spindle / hammer mechanism

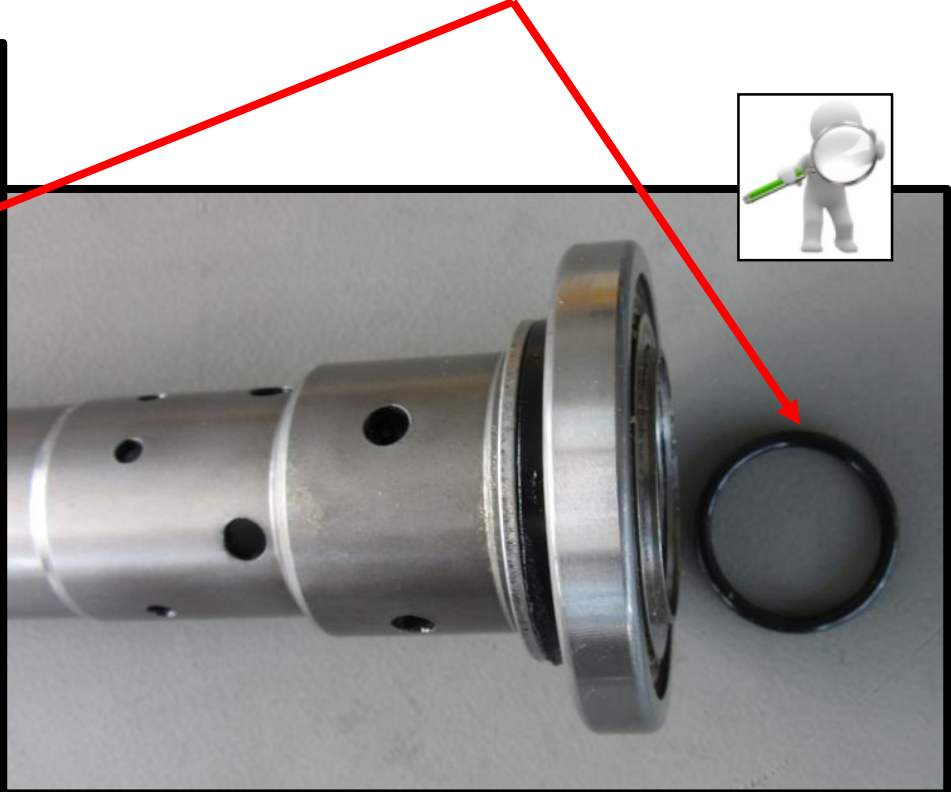
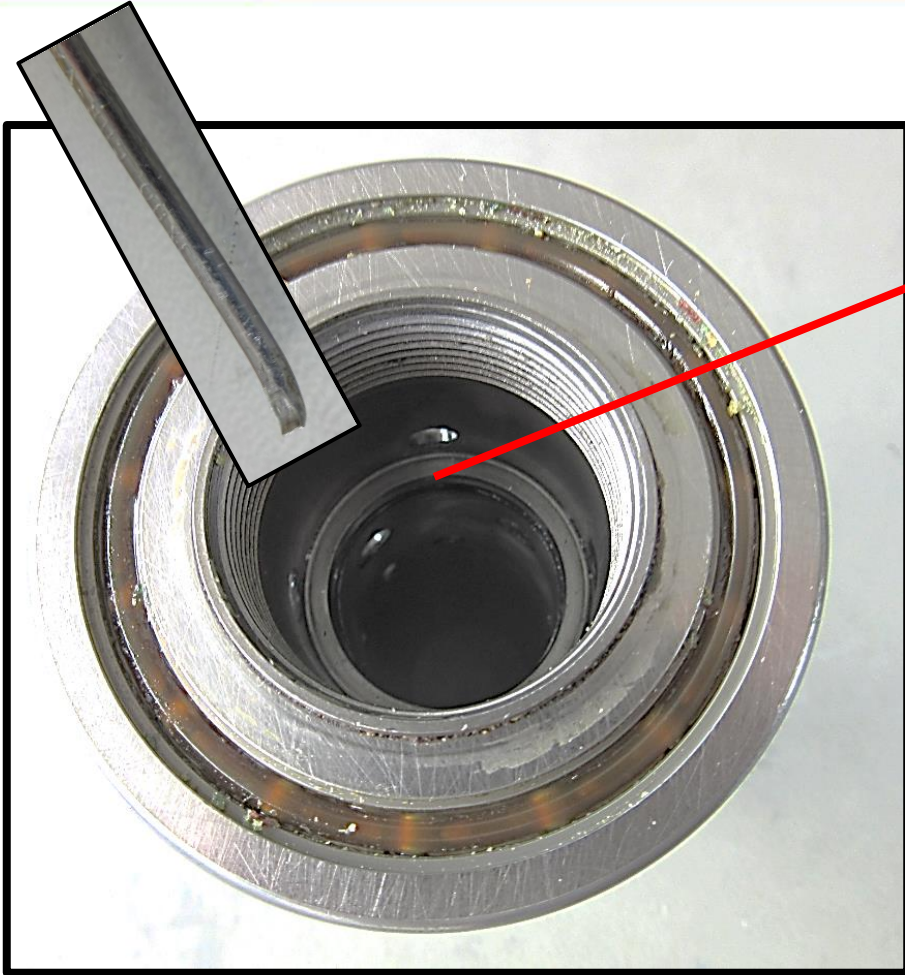

Disassembling spindle / hammer mechanism

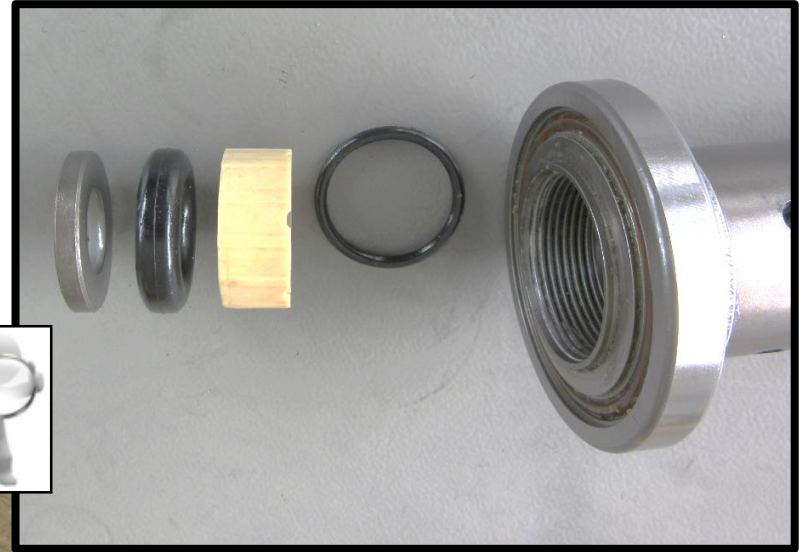
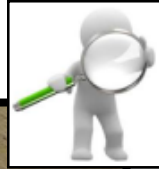

Disassembling spindle / hammer mechanism

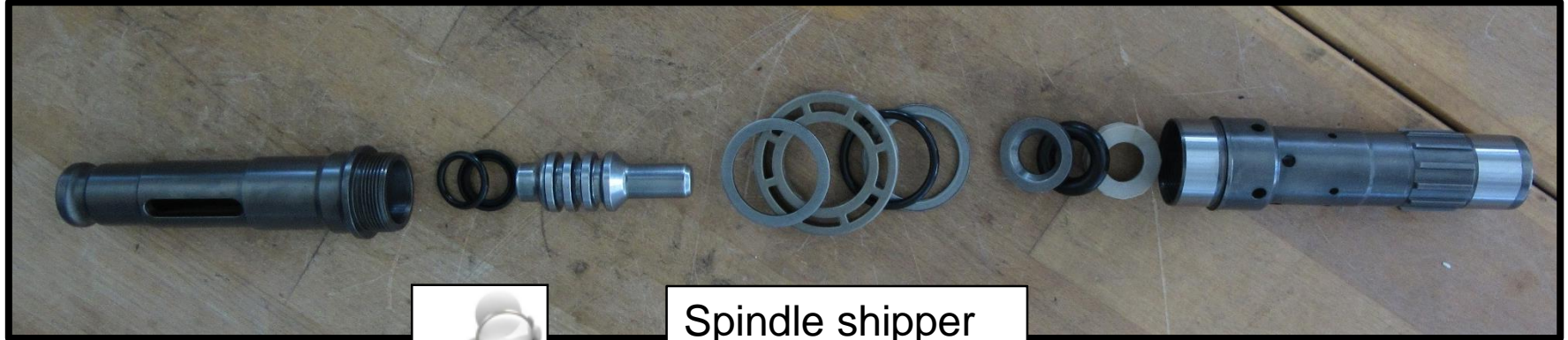

Spindle shipper



Assembling Spindle

SERVICE TOOLING 1003964-99 AND 1003965-99



Assembling spindle / hammer mechanism



Assembling spindle / hammer mechanism



Assembling spindle / hammer mechanism



ENSURE SEAL IS
IN CORRECT
ORIENTATION



Assembling spindle / hammer mechanism

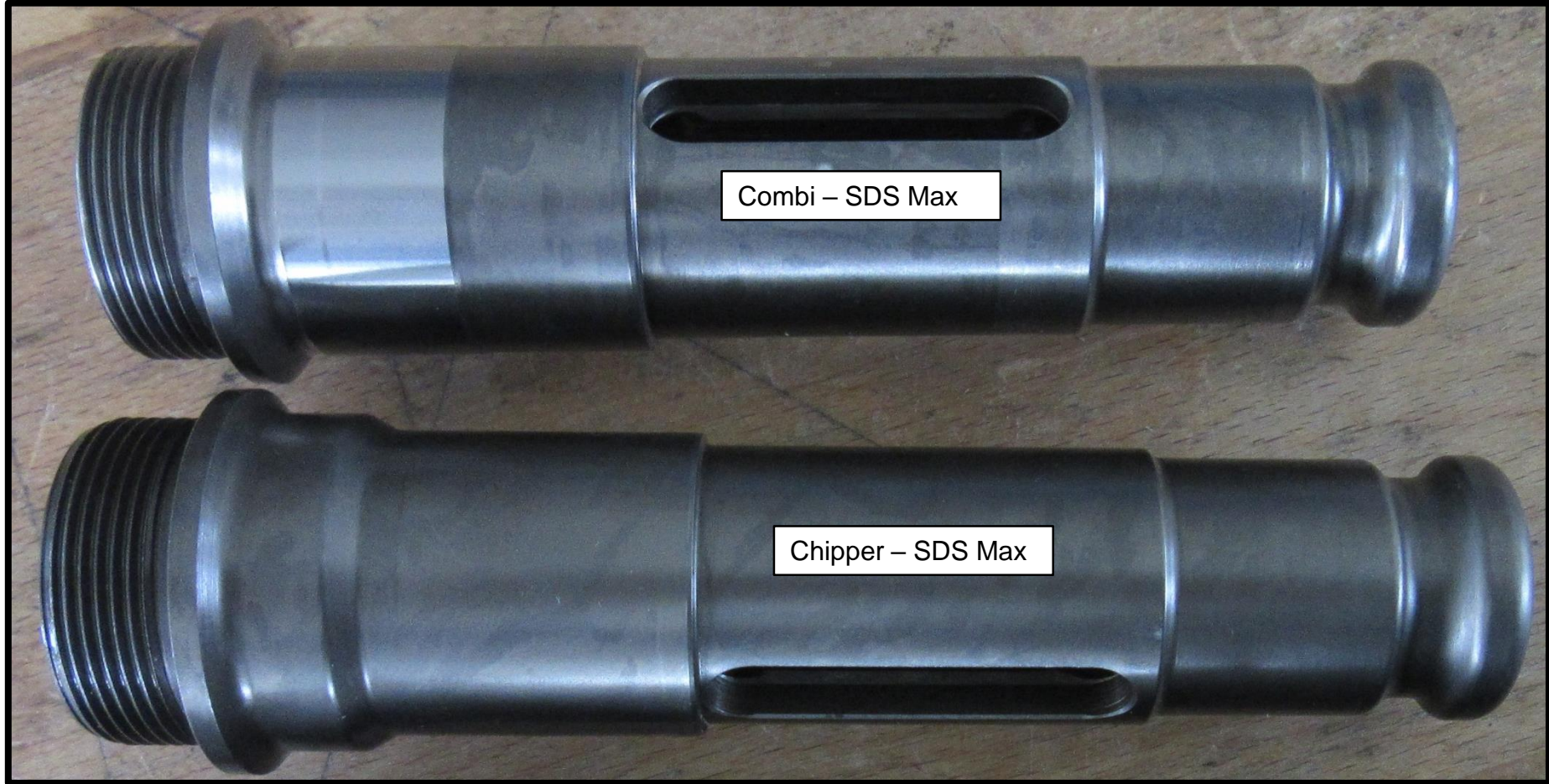

Assembling spindle / hammer mechanism

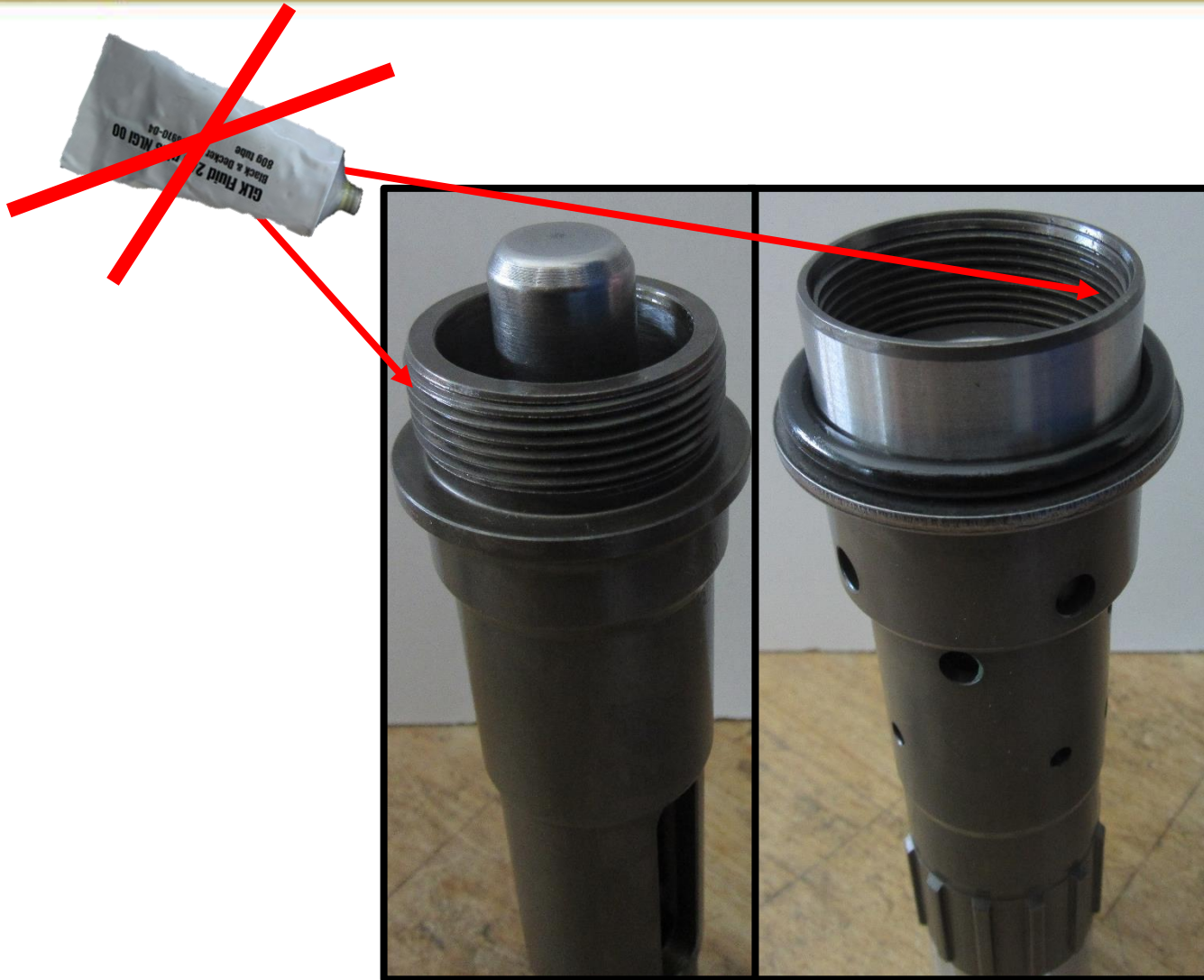

Assembling spindle / hammer mechanism



Assembling spindle / hammer mechanism

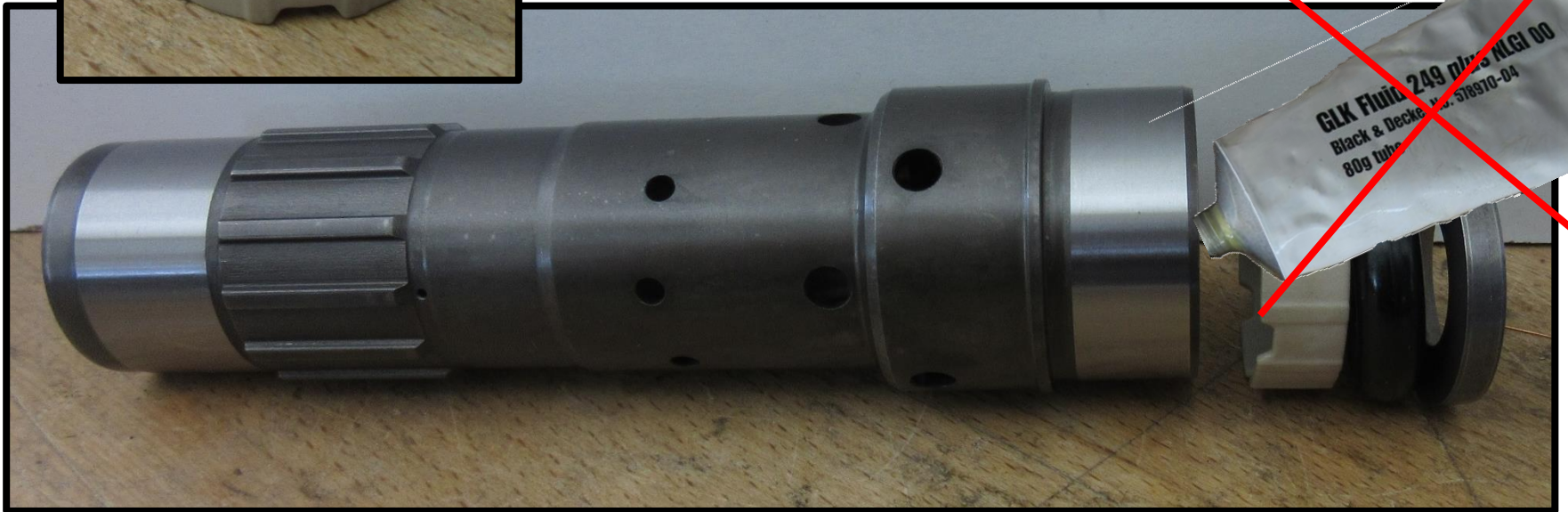

Assembling spindle / hammer mechanism



Assembling spindle / hammer mechanism

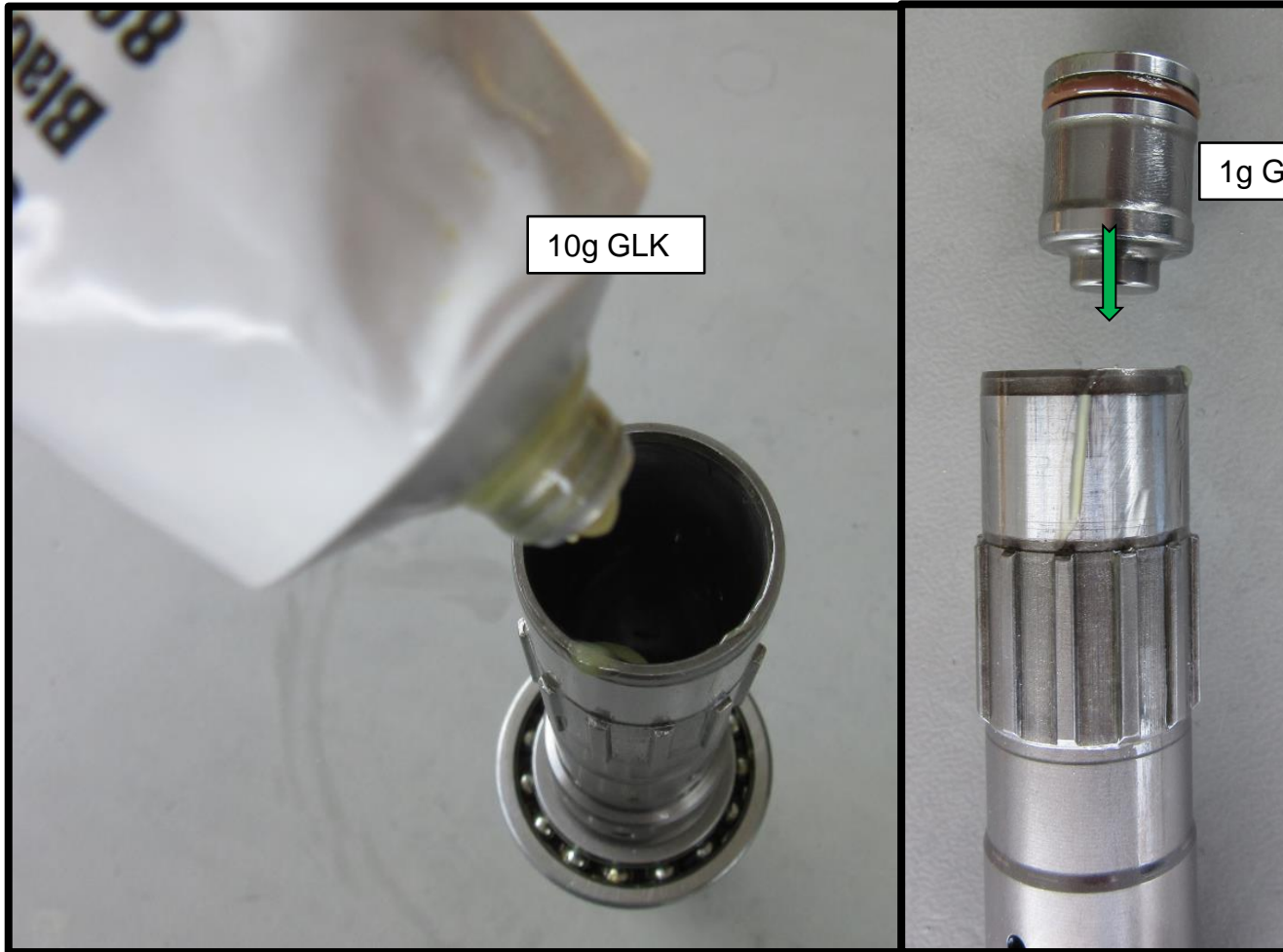

Assembling spindle / hammer mechanism



Assembling spindle / hammer mechanism



Assembling spindle / hammer mechanism



Assembling spindle / hammer mechanism



Assembling spindle / hammer mechanism



Assembling spindle / hammer mechanism



This assembly was till WK52 2017

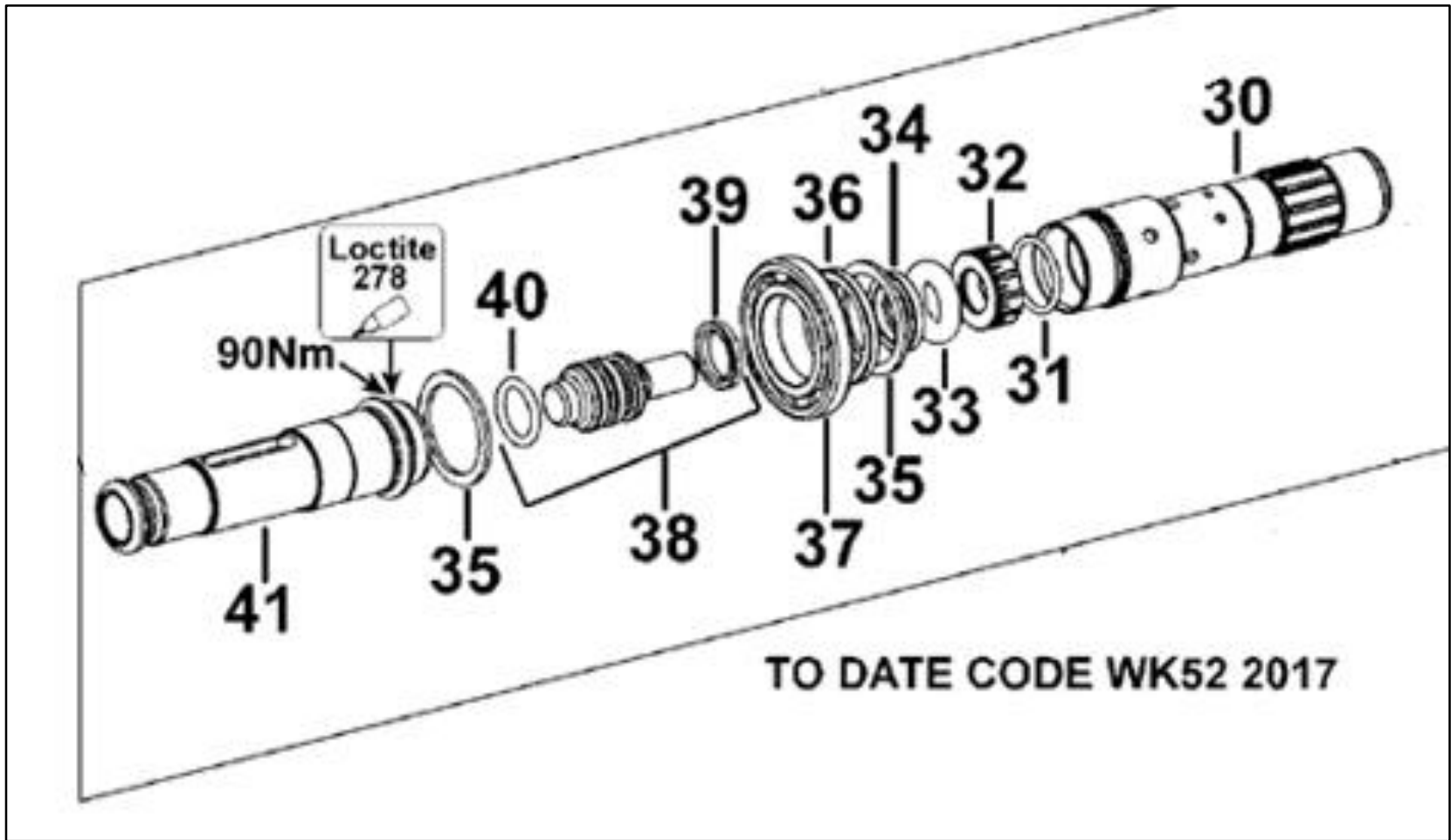



Assembling from WK01 2018

Combi Units

Spindle design Combi from WK01 2018

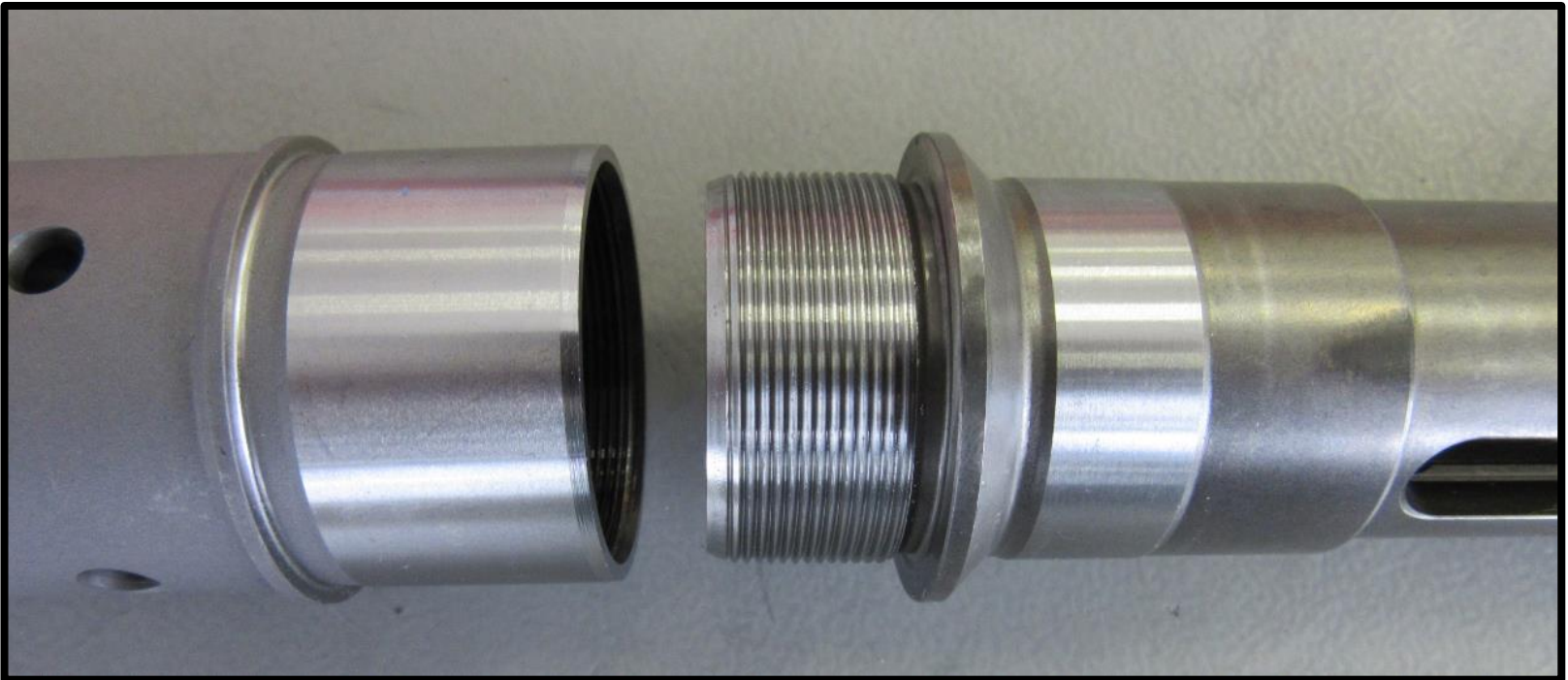
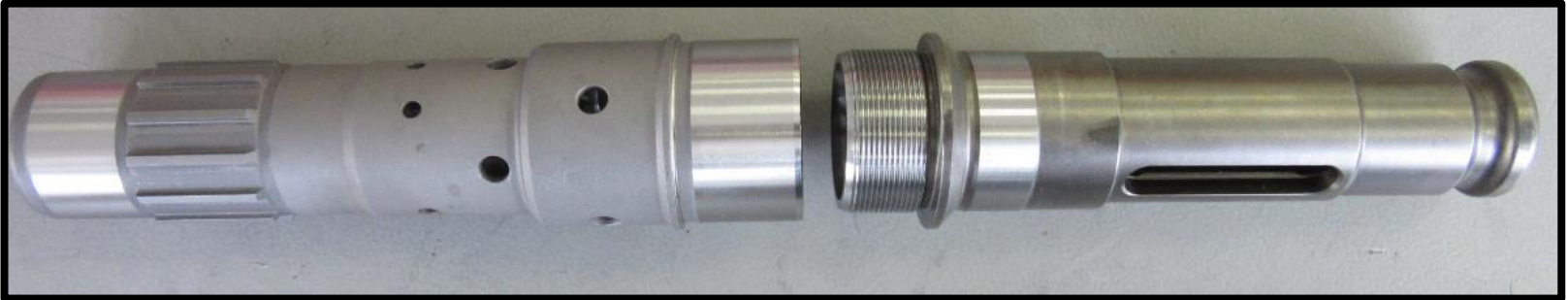

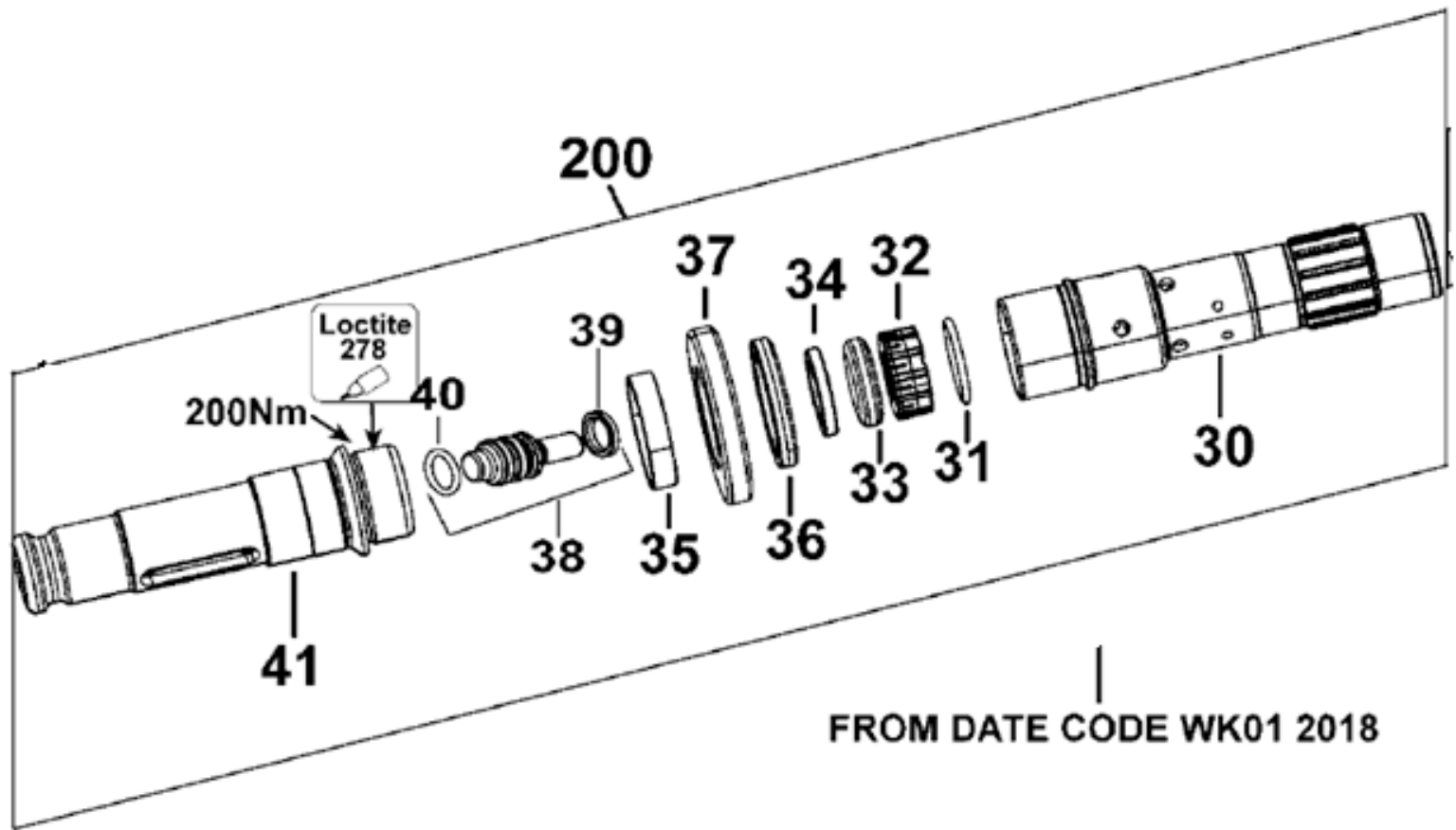



Assembling from WK01 2018

Chipper Unit

Spindle design shipper



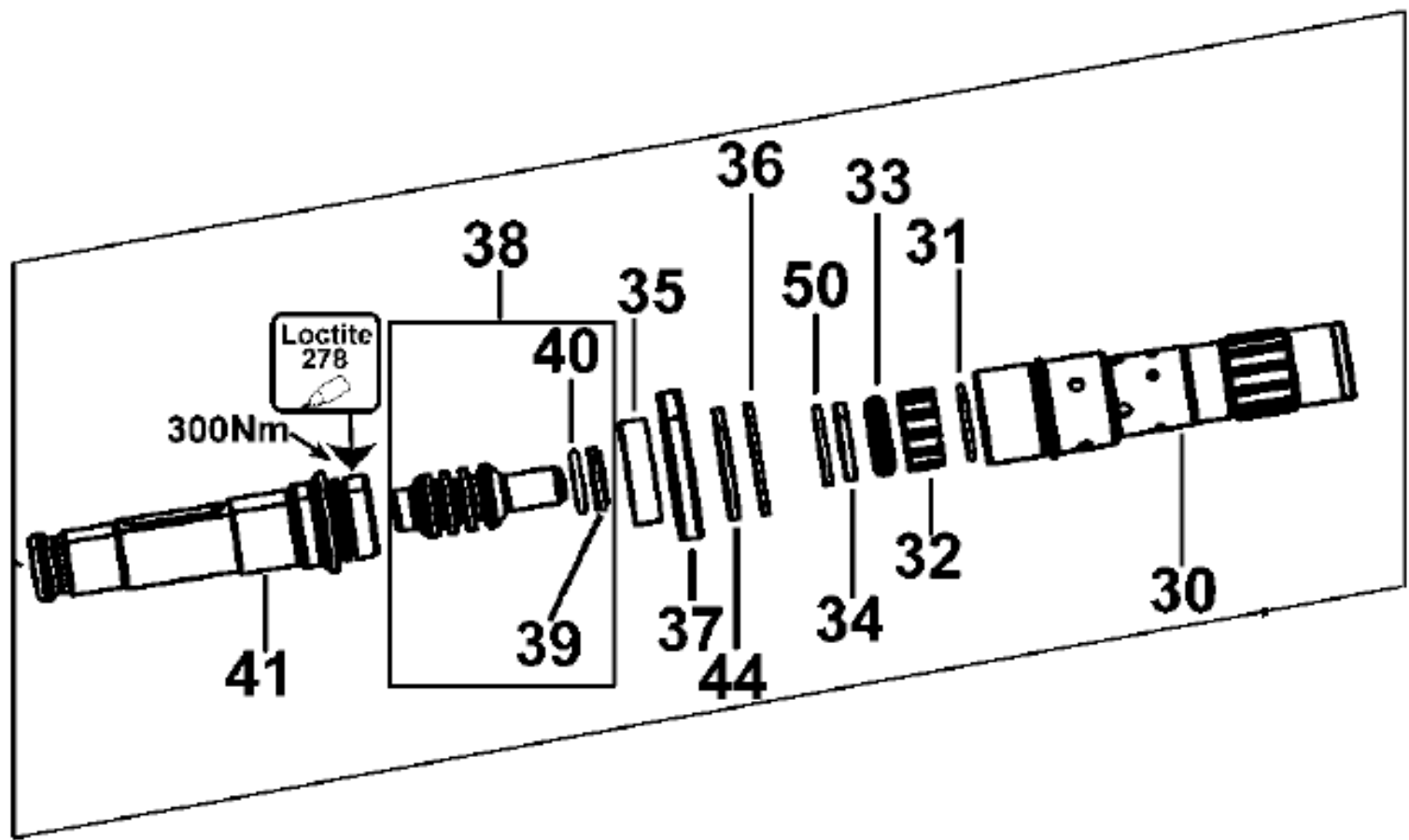



Disassembling housing

Disassembling Gear Housing

Disassembling housing



Disassembling housing



Disassembling housing

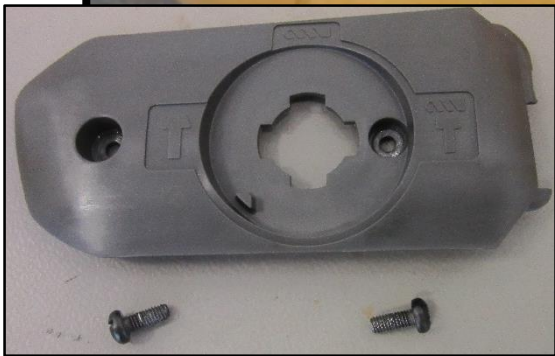
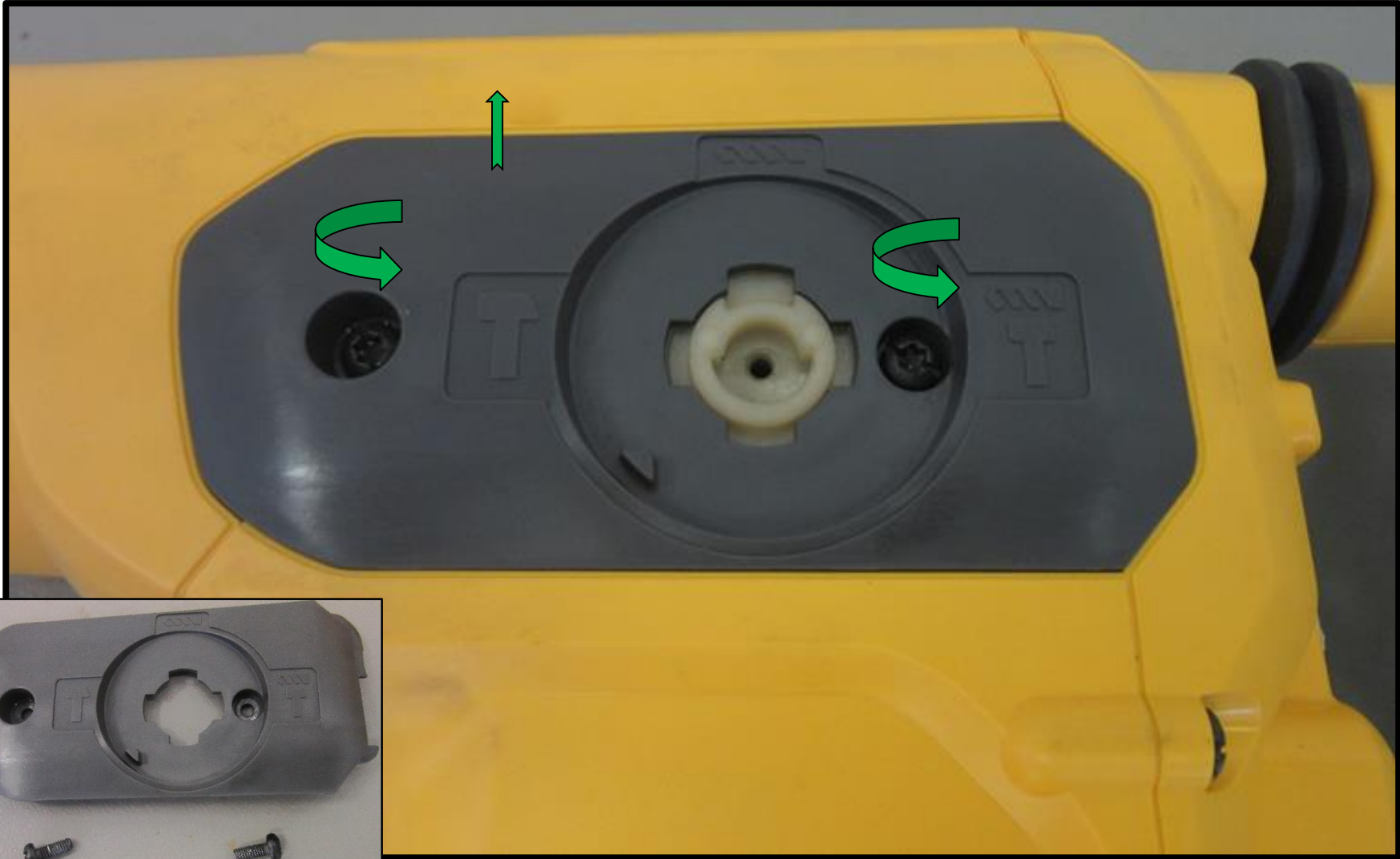

Disassembling housing



Disassembling housing

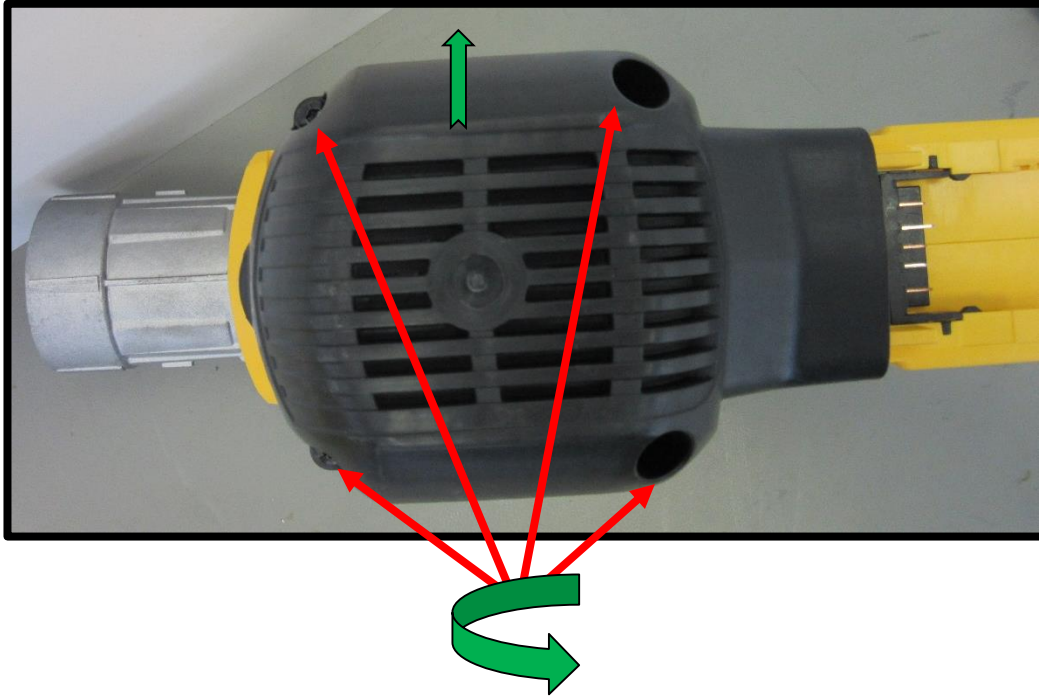

Disassembling housing

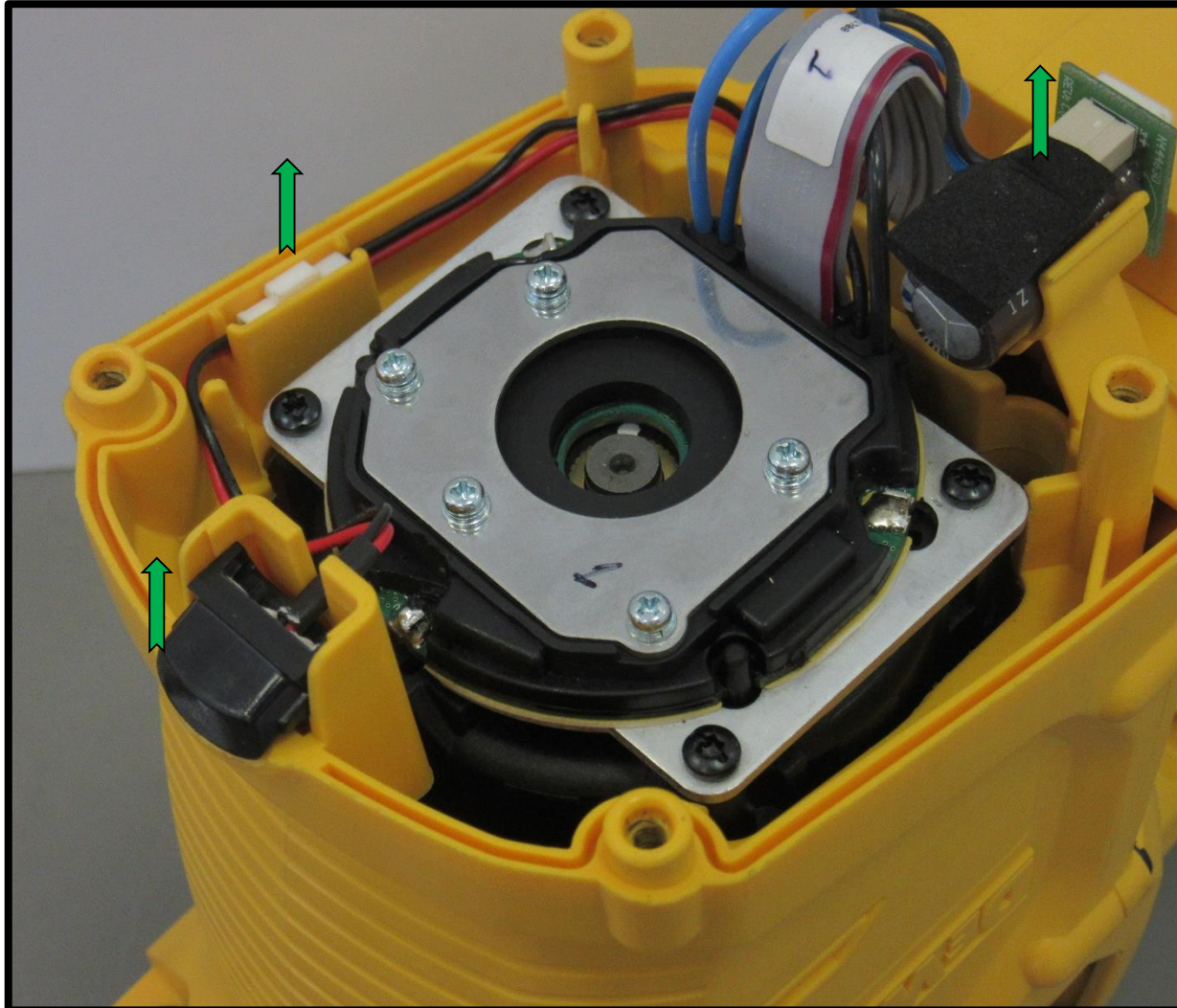

Disassembling housing

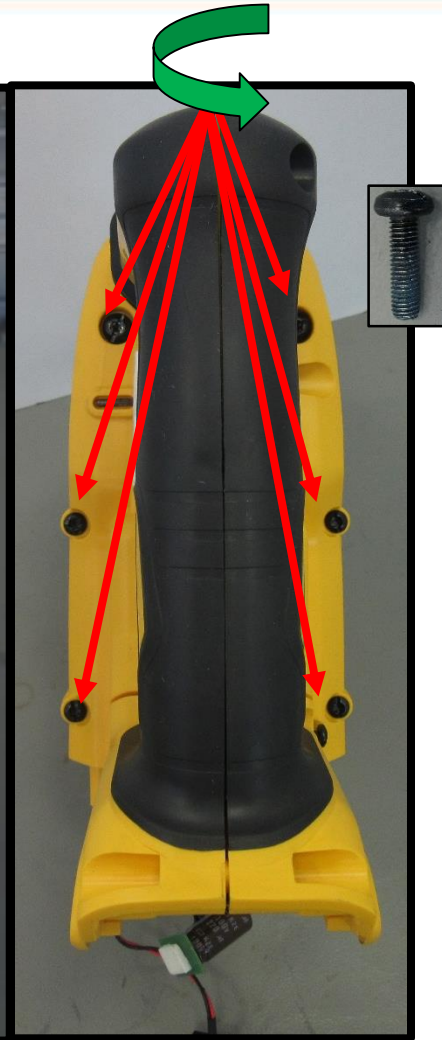
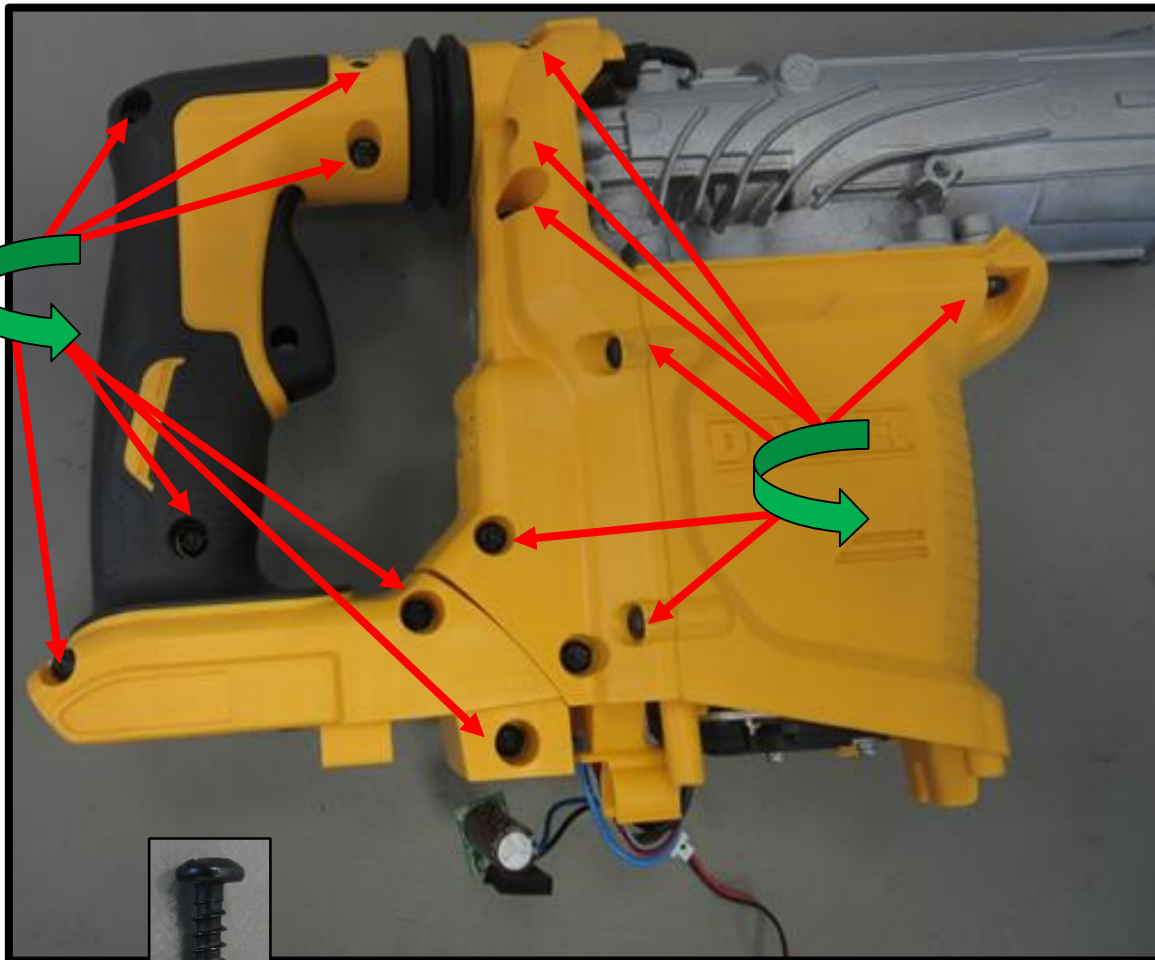

Disassembling housing



Disassembling housing/electrical components

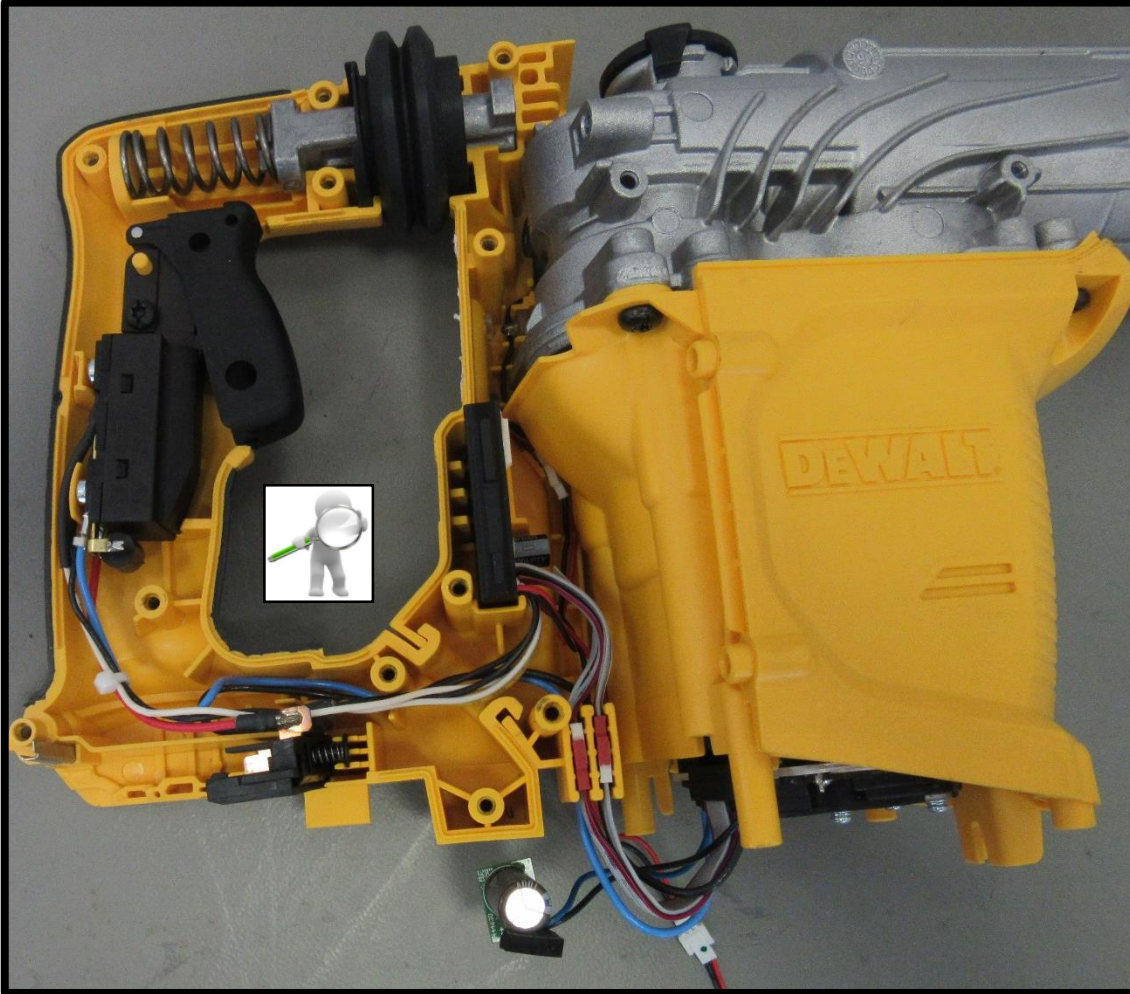

Disassembling housing/electrical components

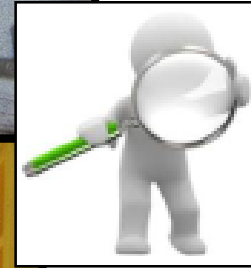
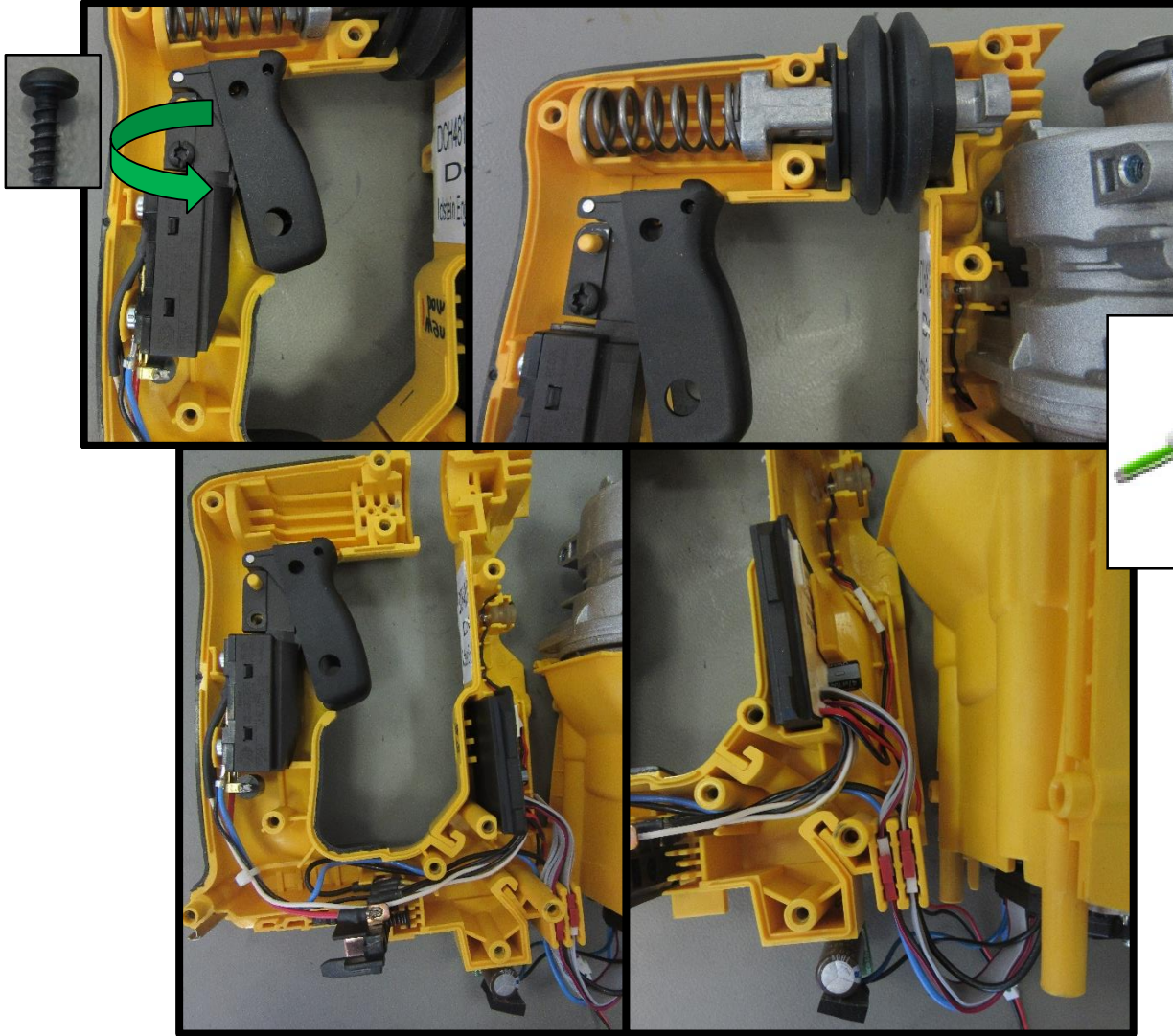

Disassembling housing/electrical components

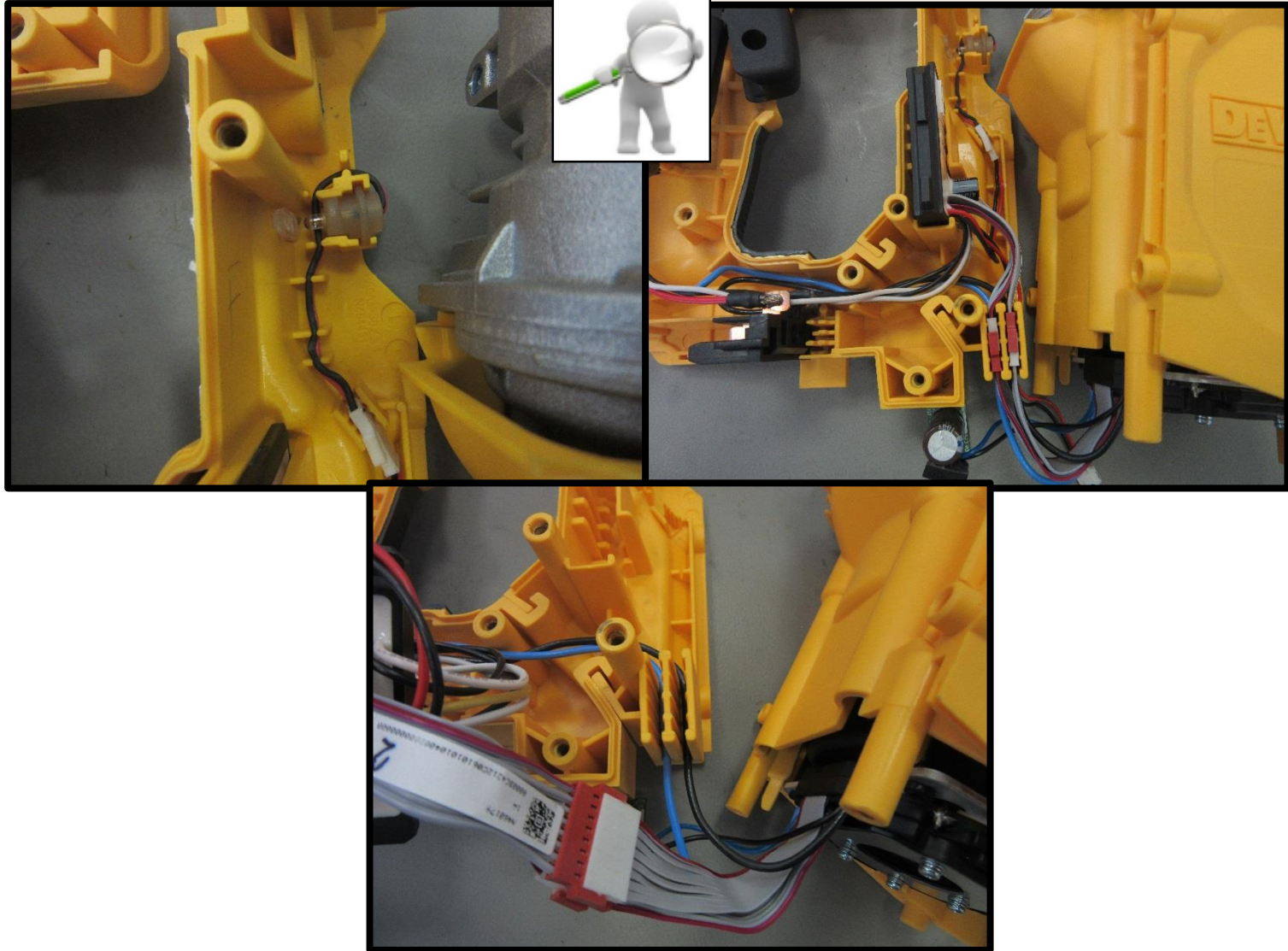

Disassembling housing/electrical components

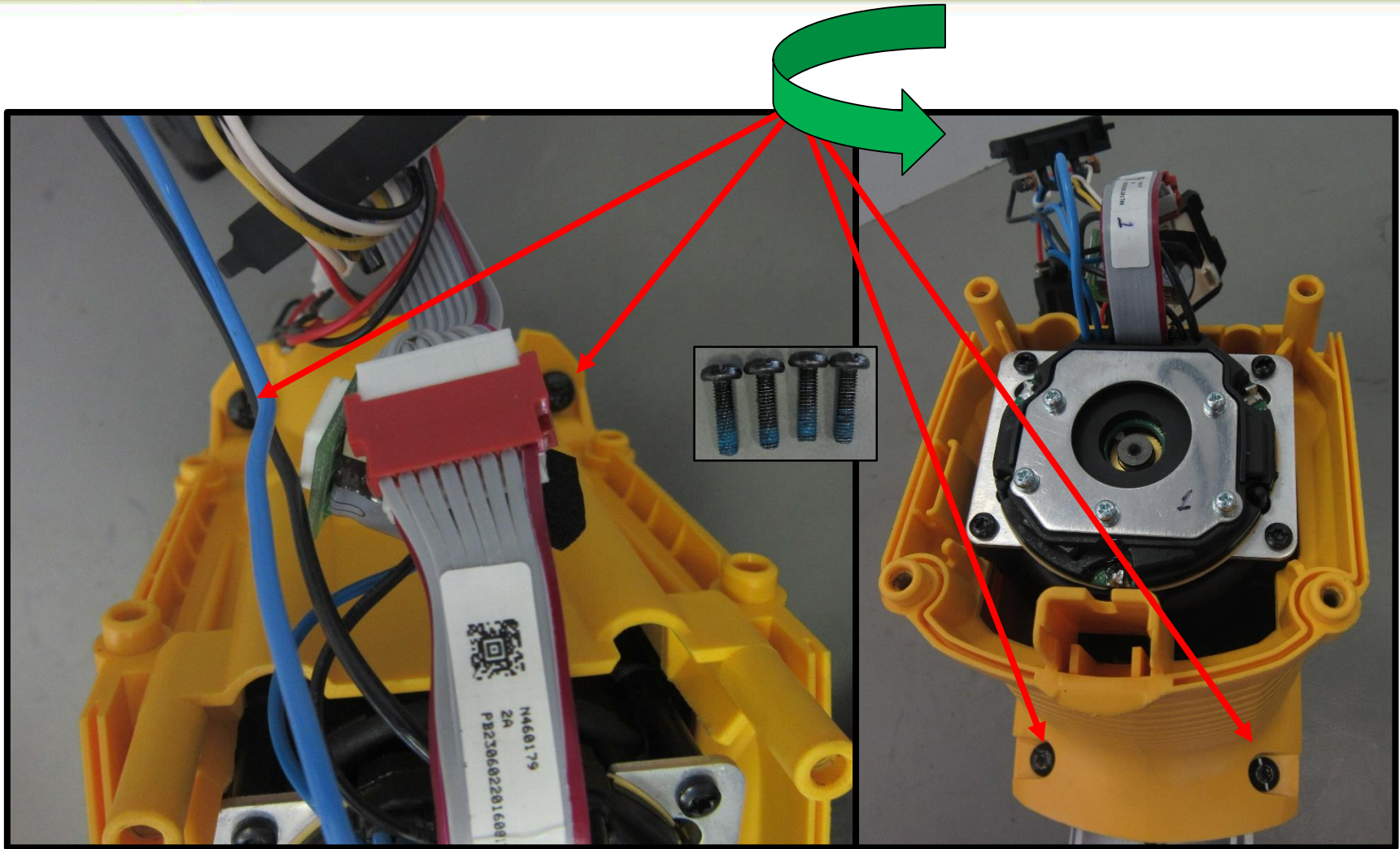

Disassembling housing/electrical components

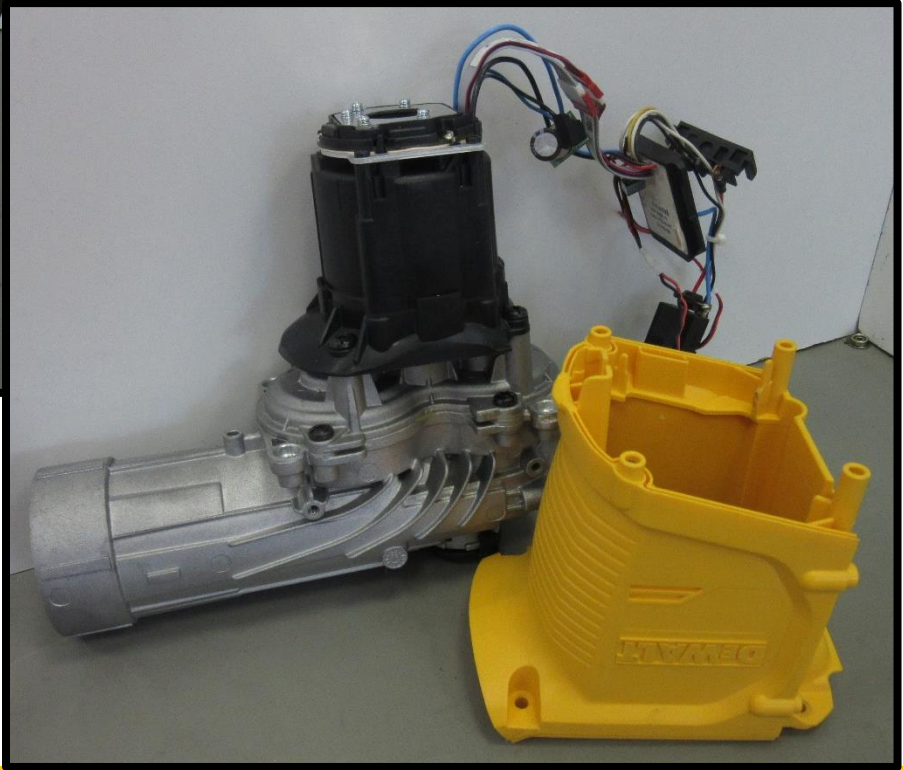
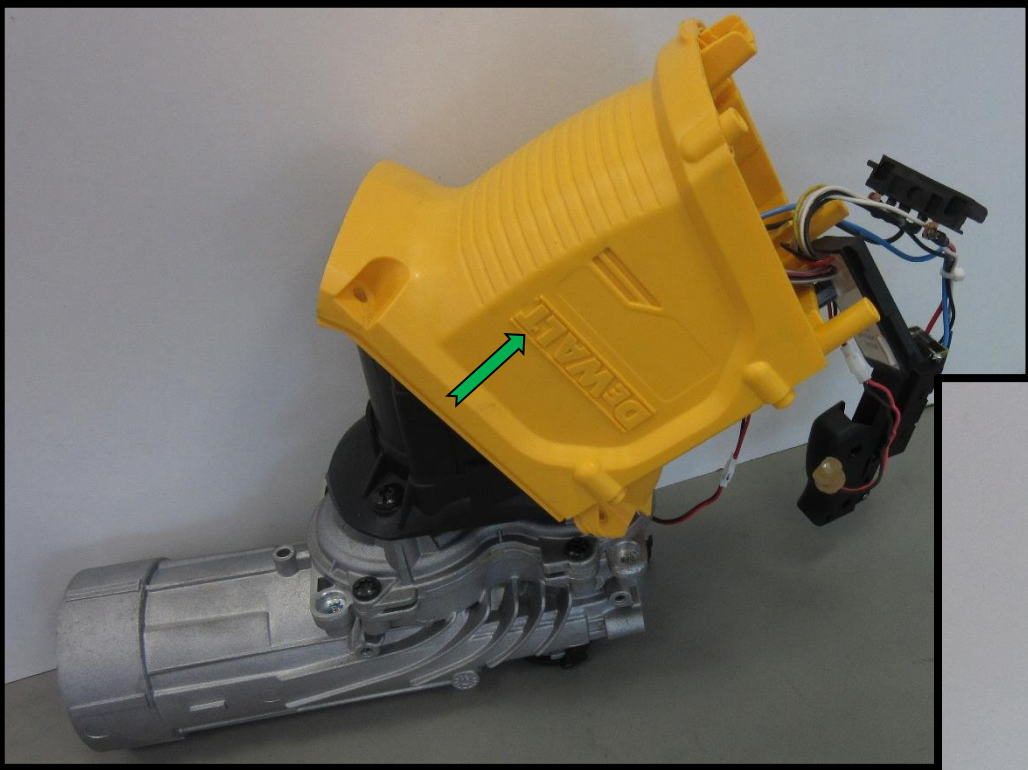

Disassembling gear housing

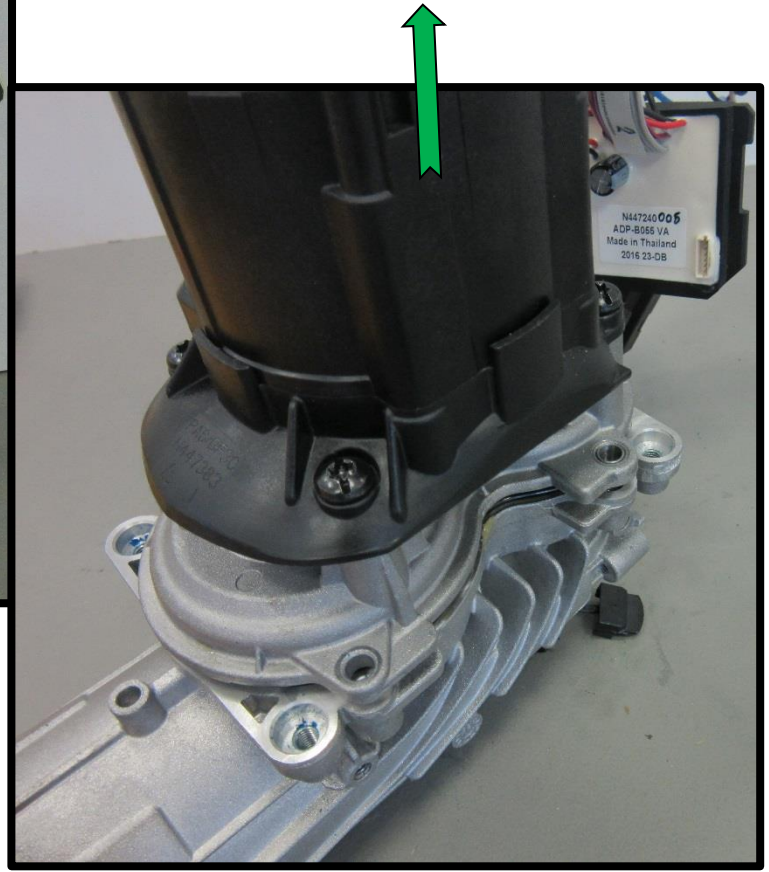
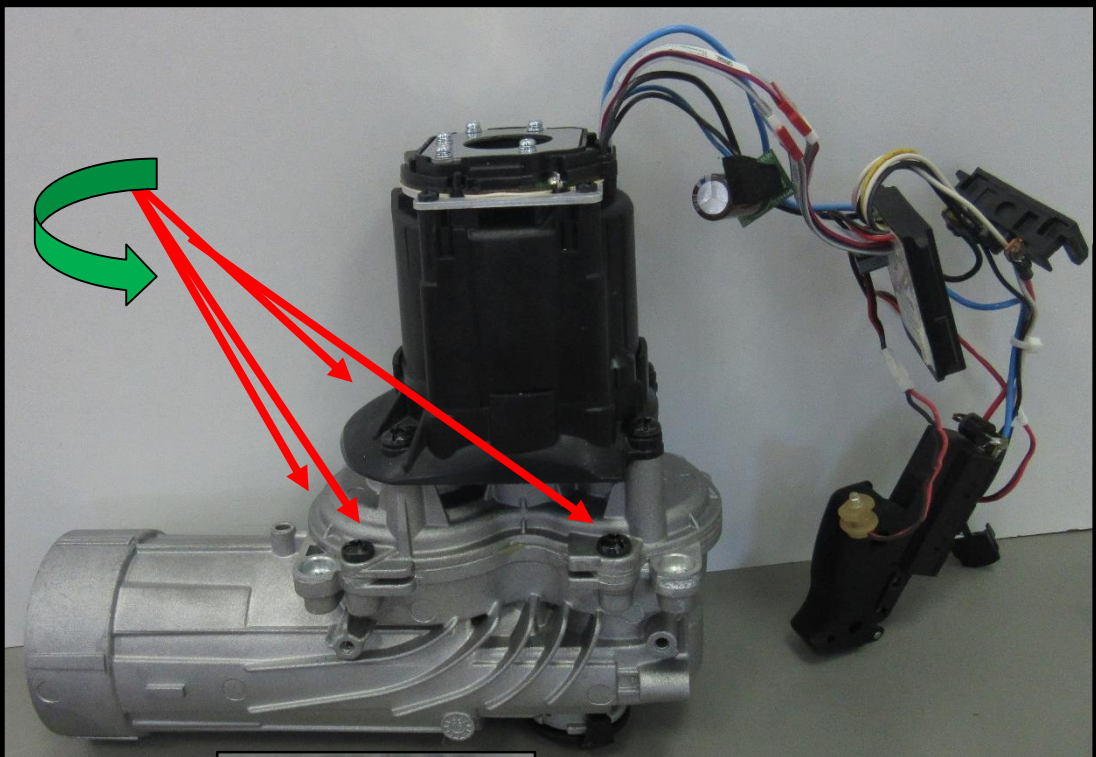

Disassembling gear housing

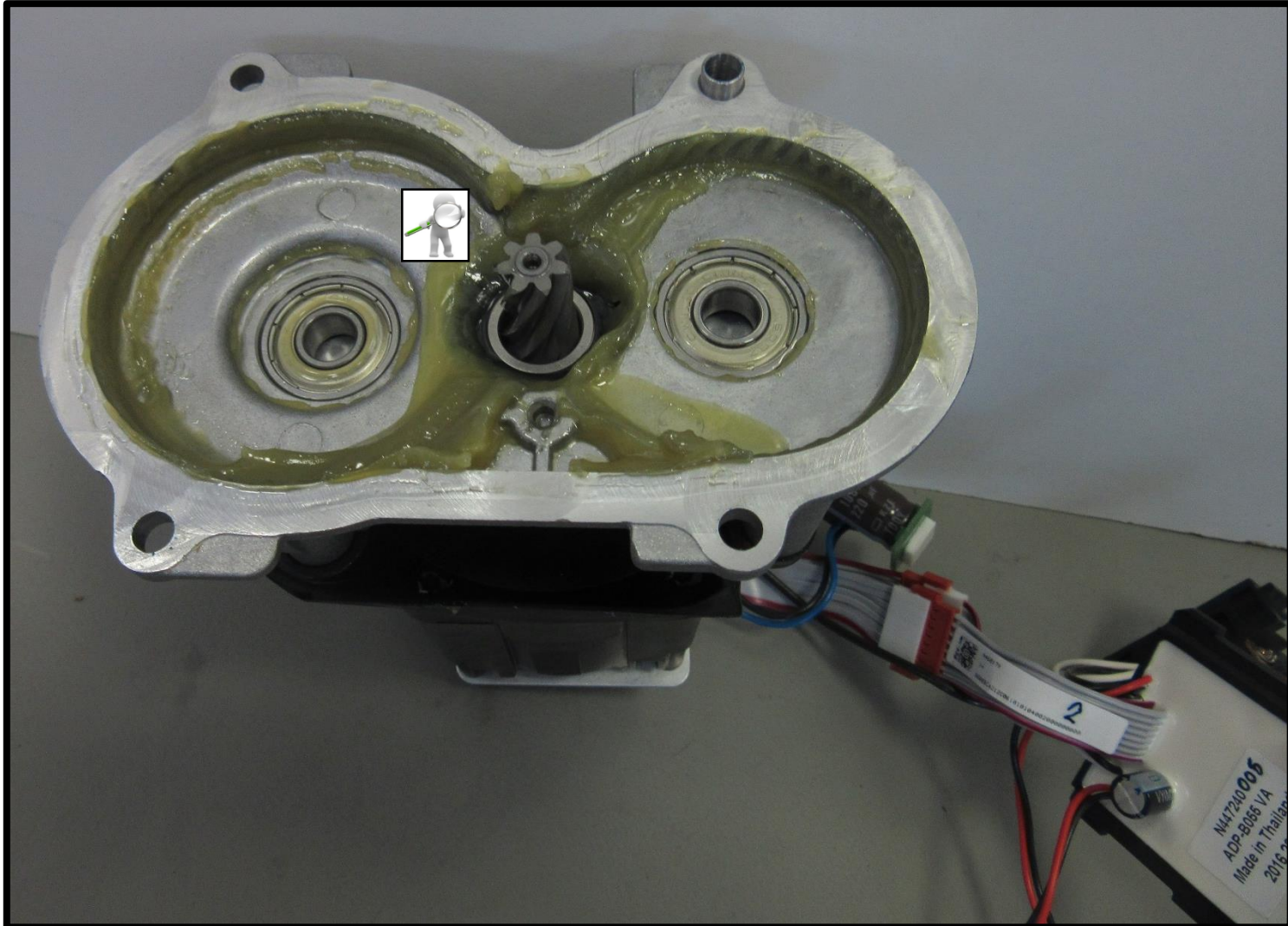

Disassembling gear housing

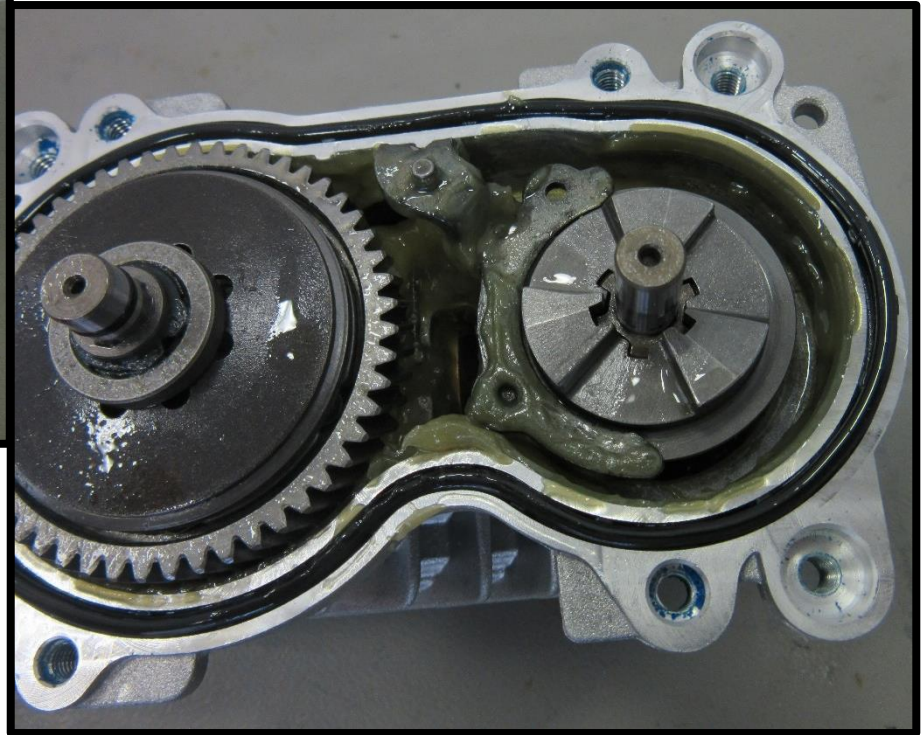
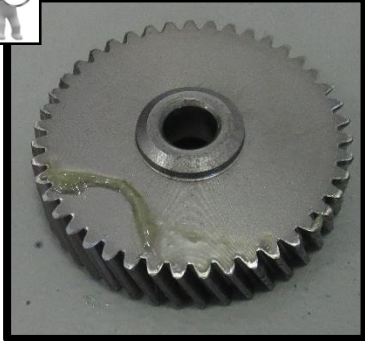
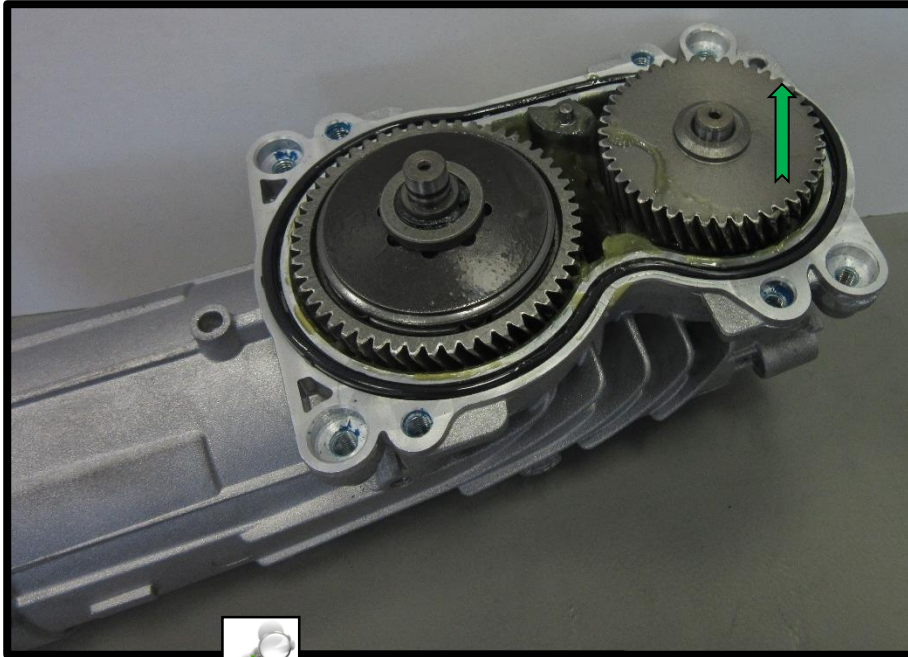

Disassembling gear housing

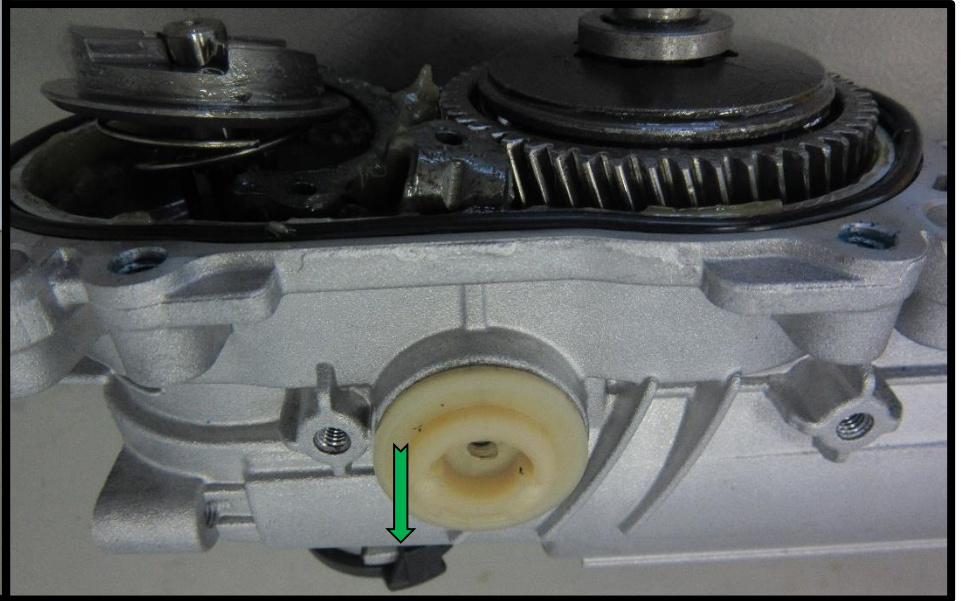
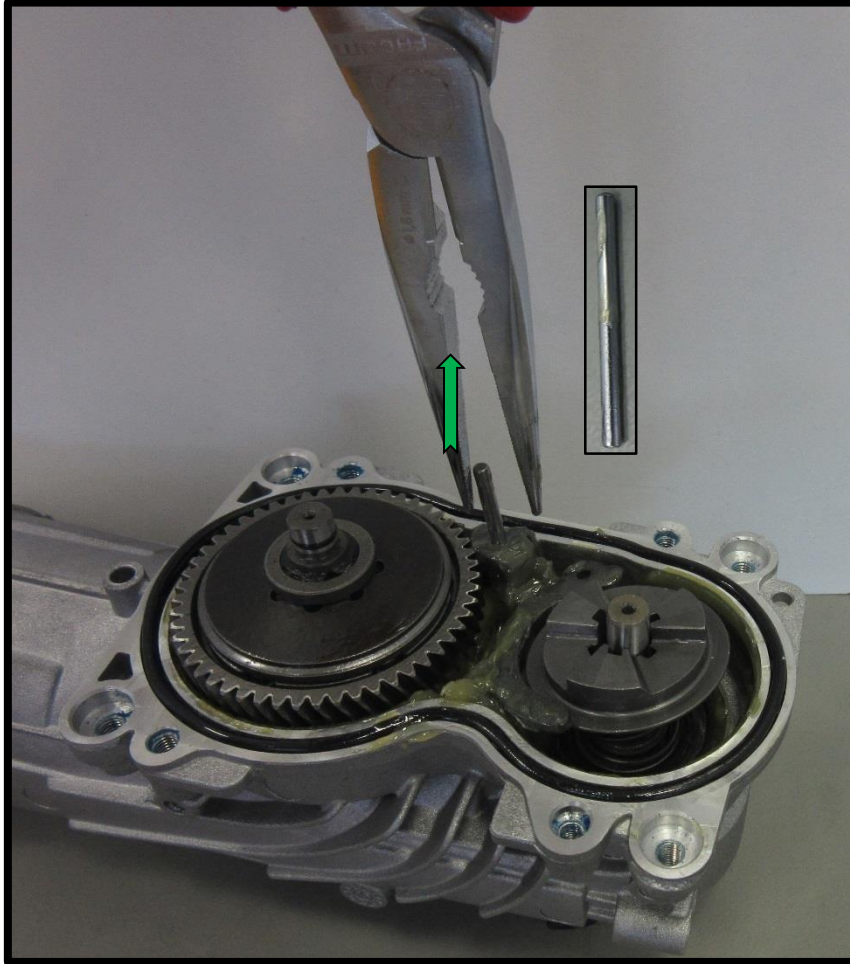

Disassembling gear housing

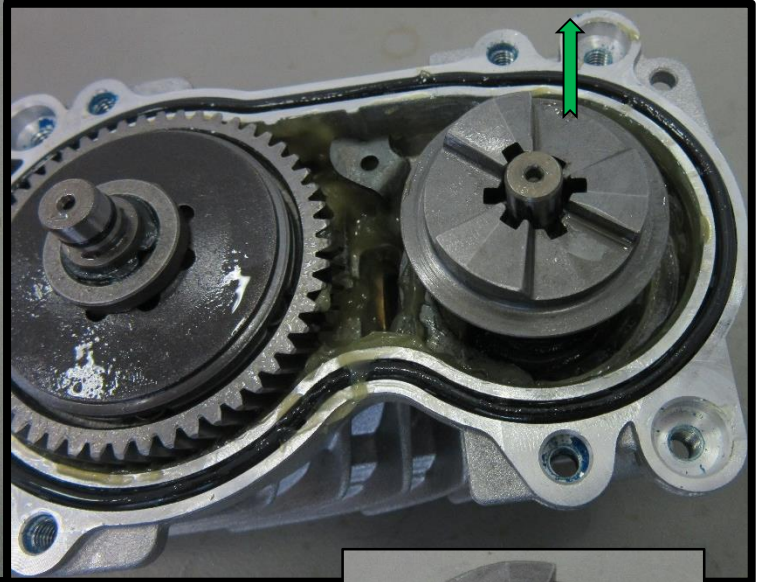
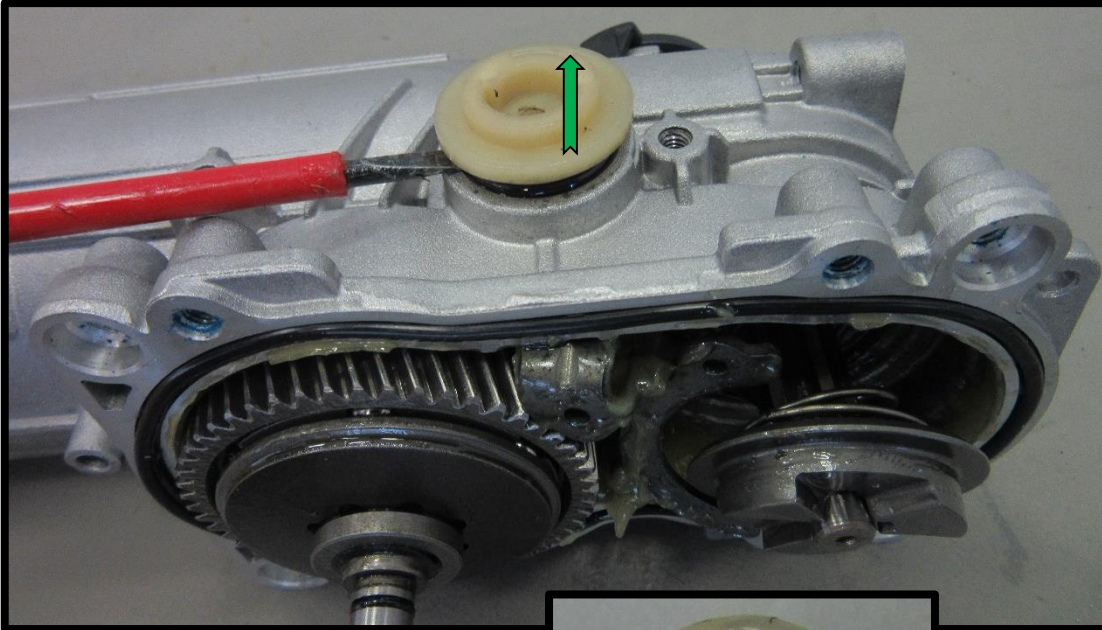

Disassembling gear housing

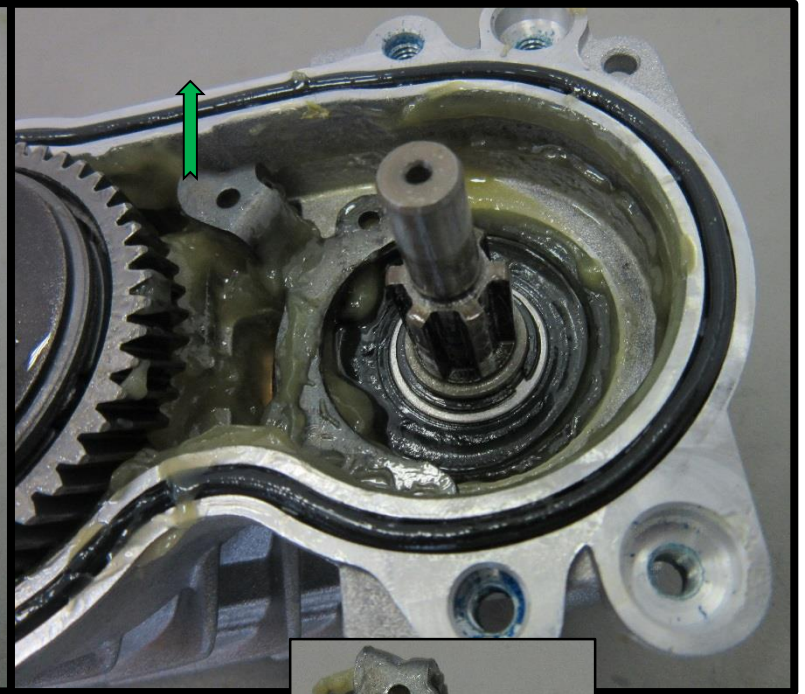
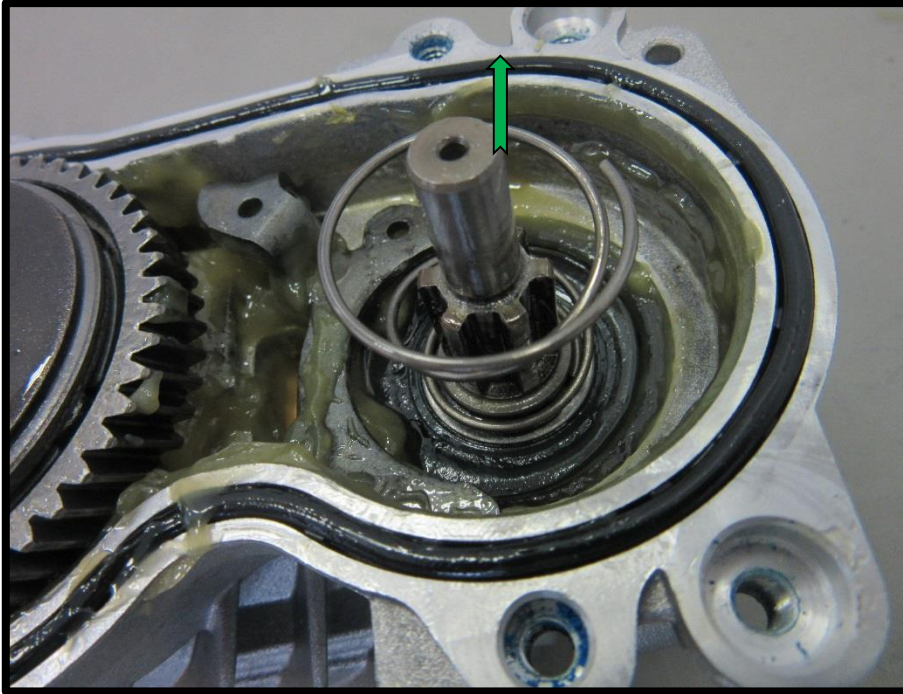

Disassembling gear housing

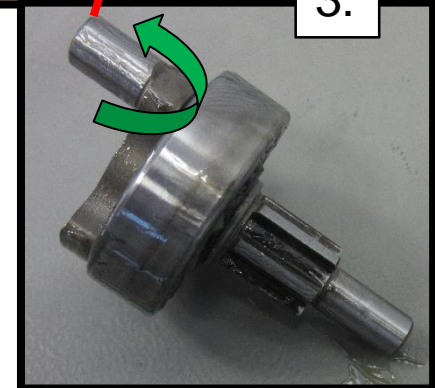
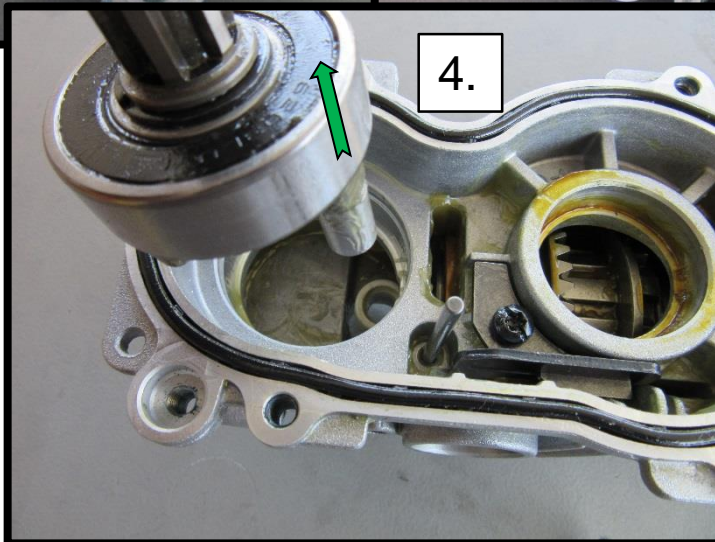
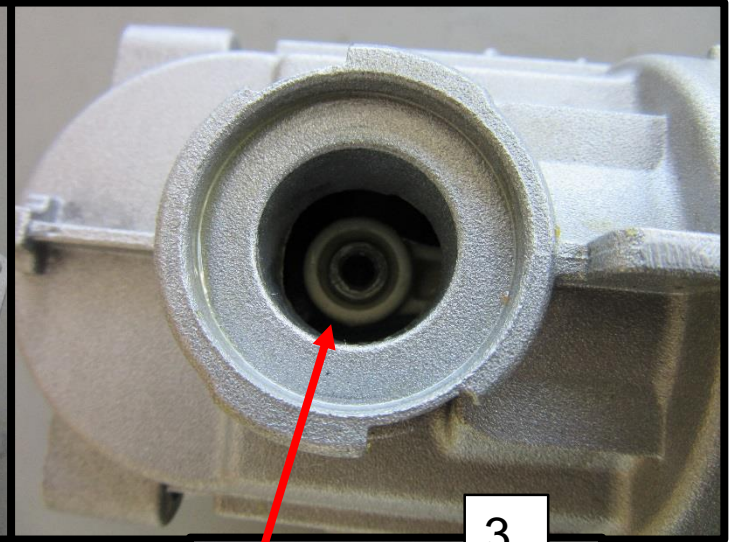
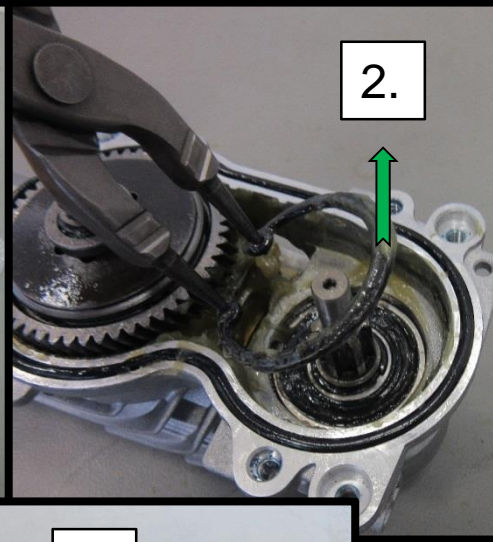
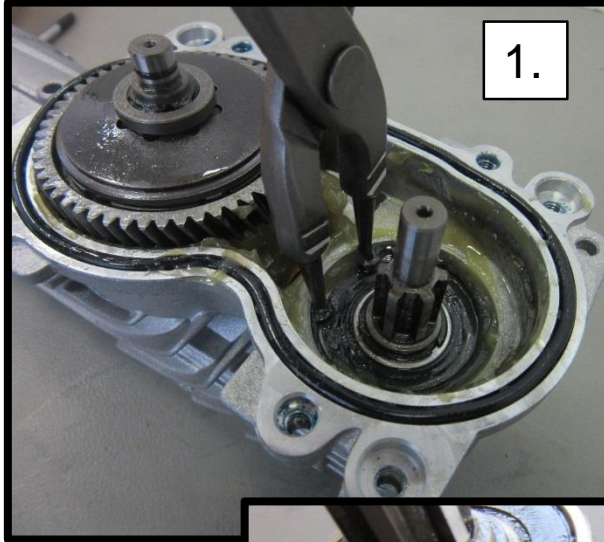

Disassembling gear housing

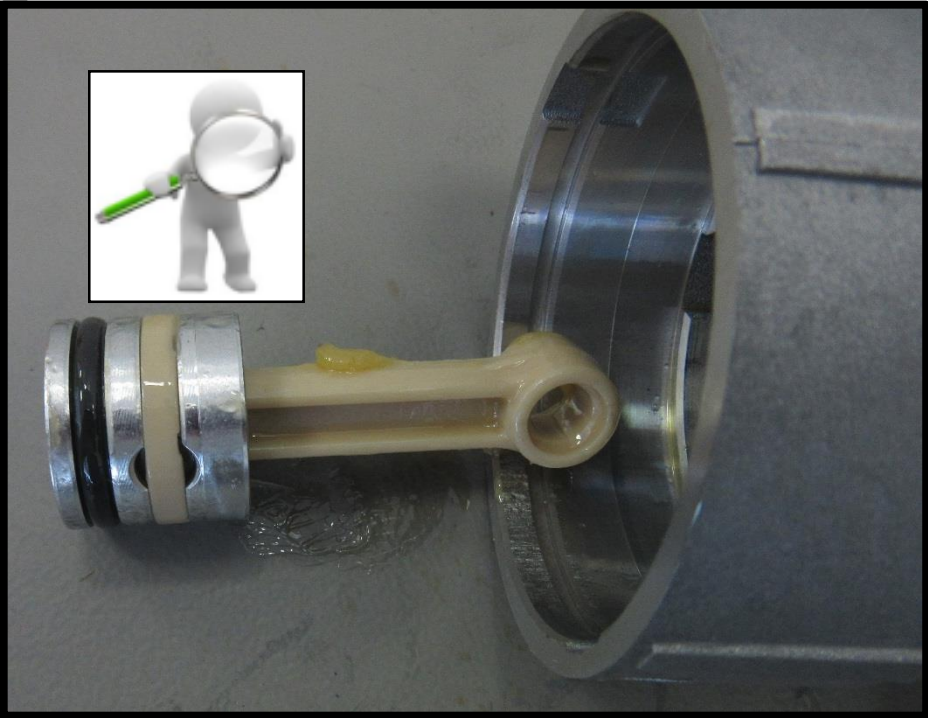
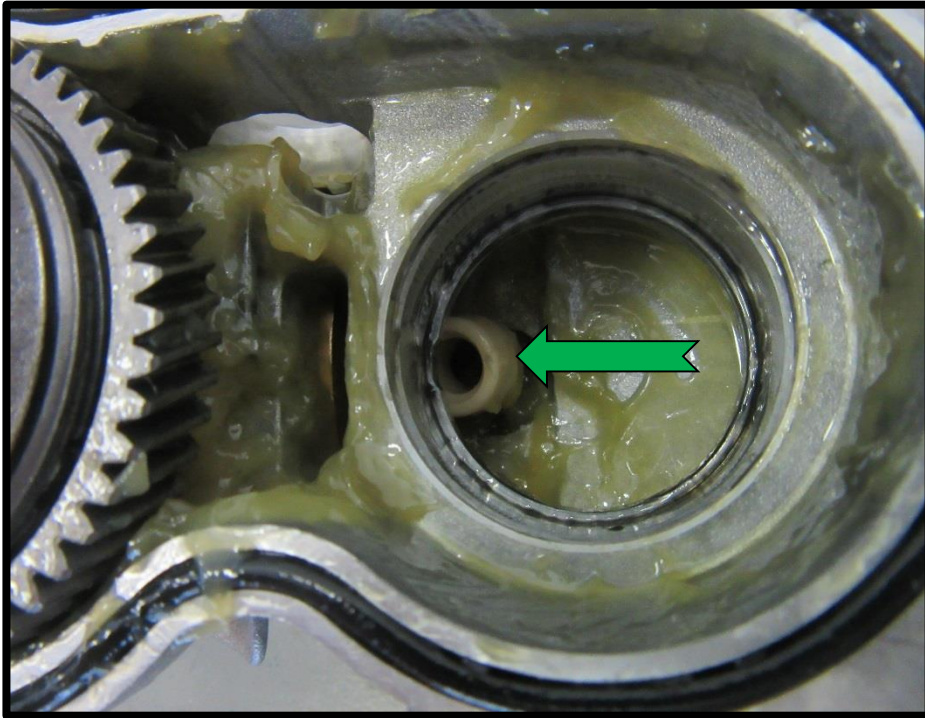

Disassembling gear housing

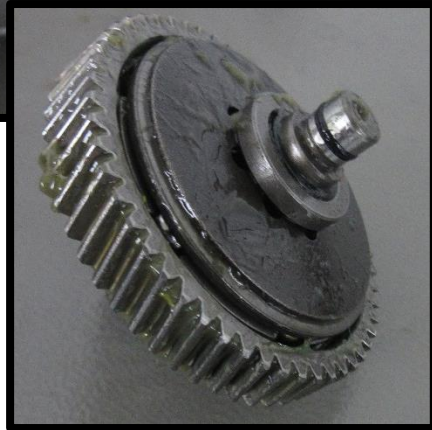
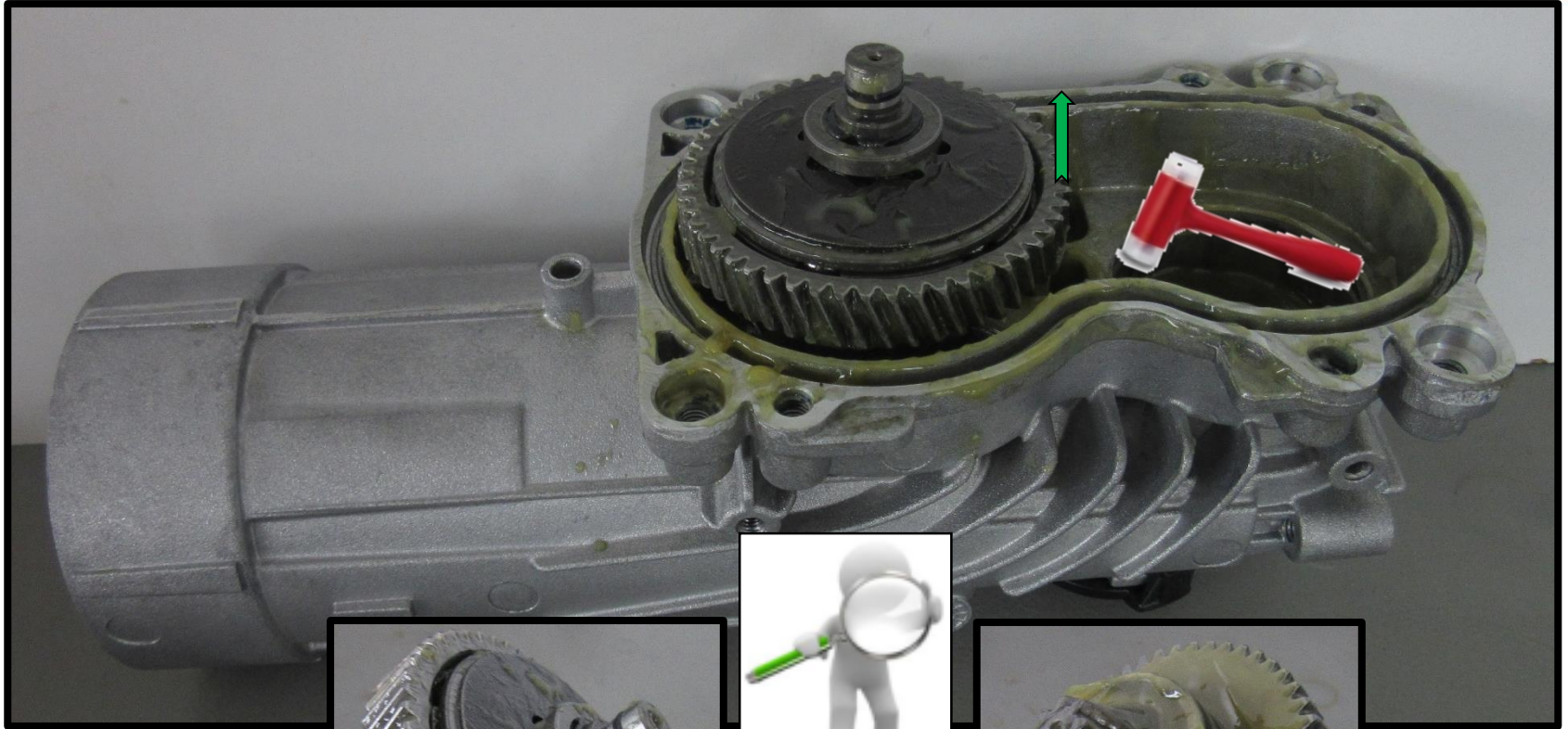

Disassembling gear housing

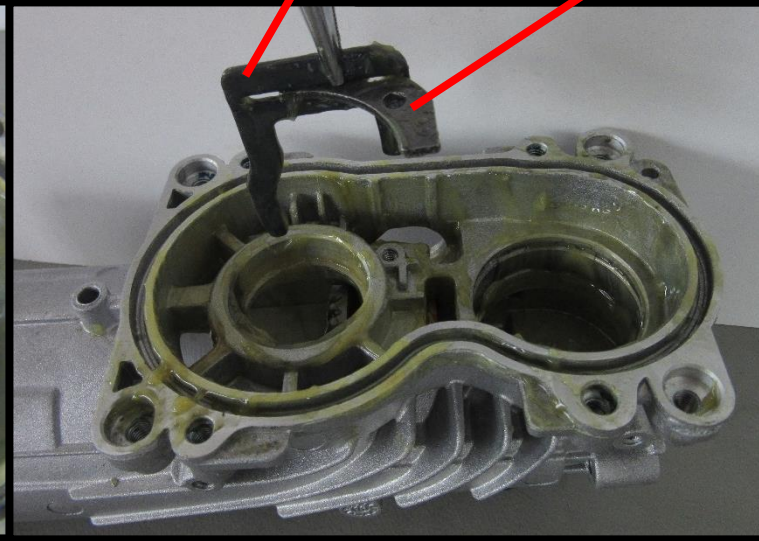
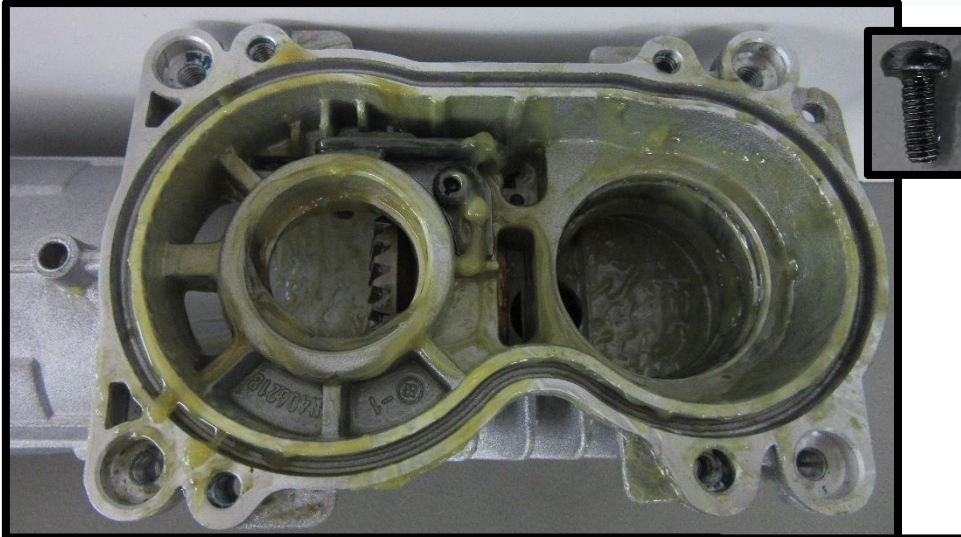

Disassembling gear housing

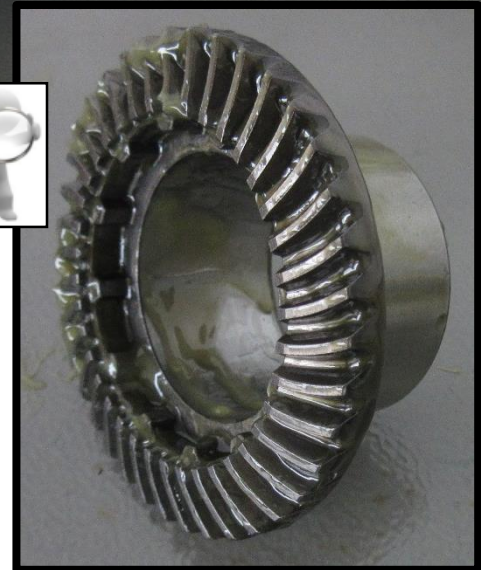
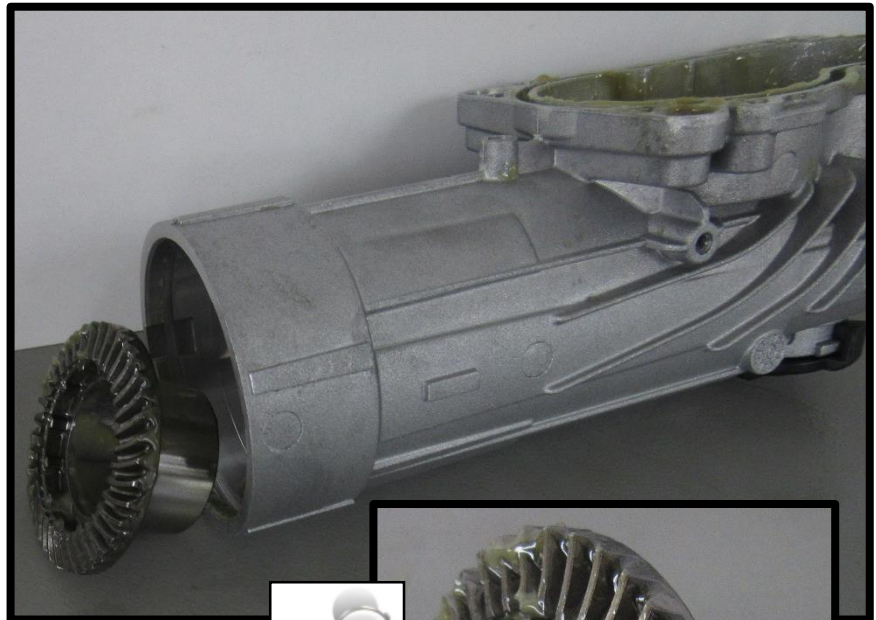
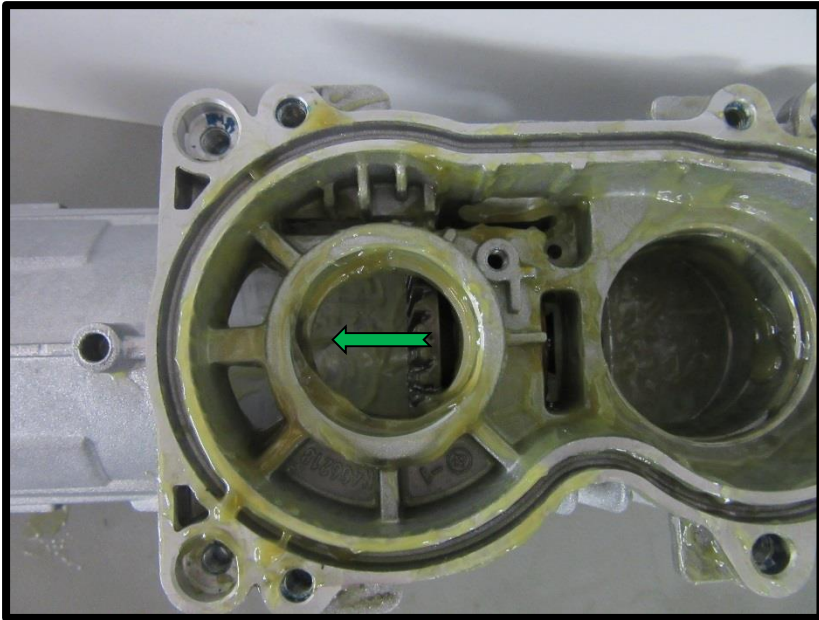

Disassembling electrical module

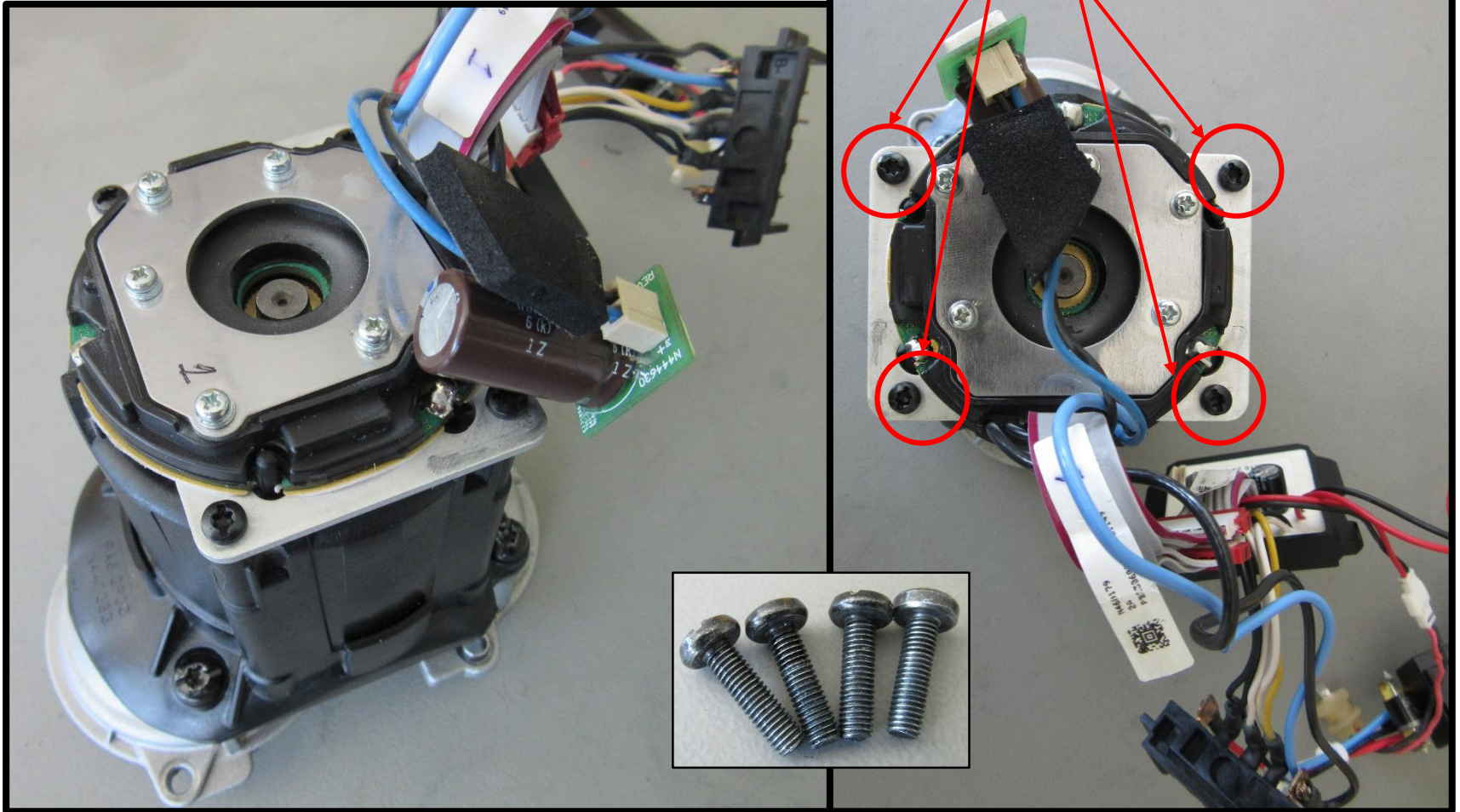

Disassembling electrical module

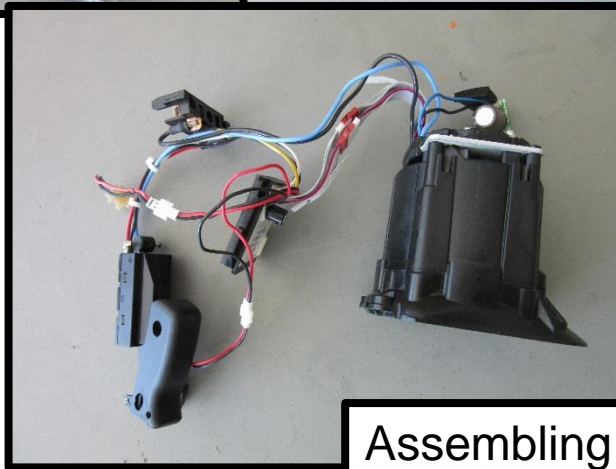
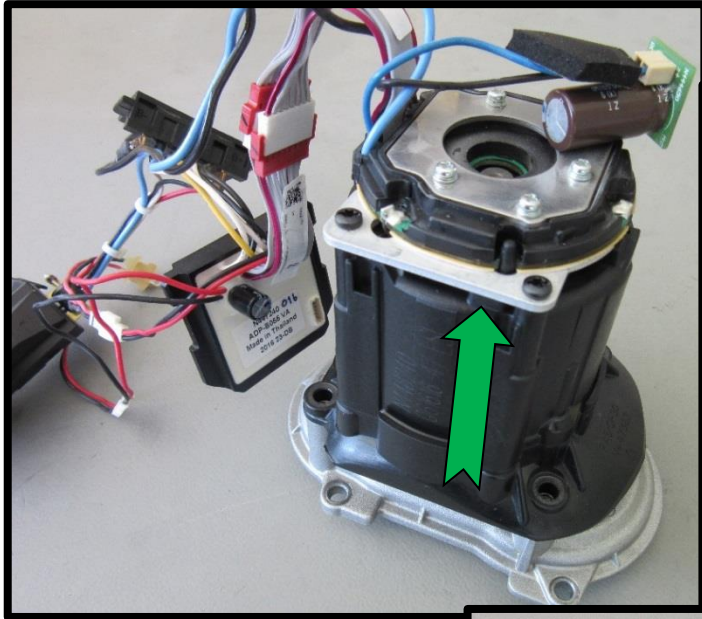

Assembling Module

Disassembling armature

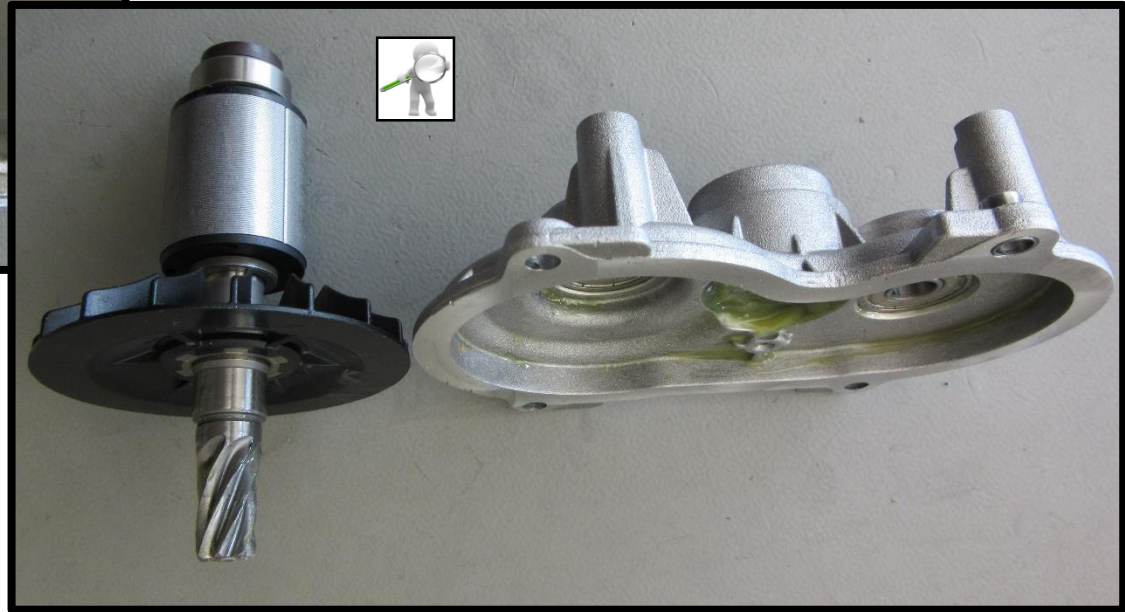
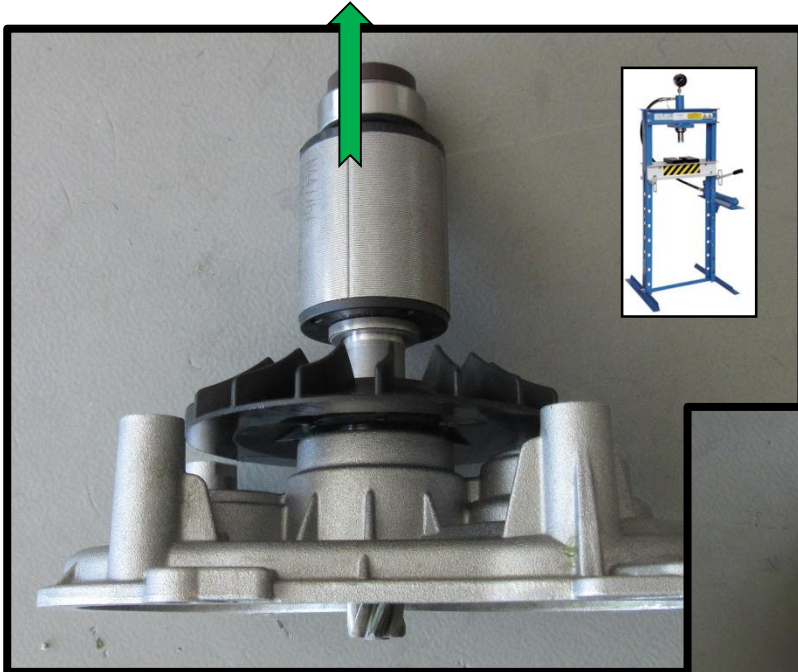

Disassembling bearings

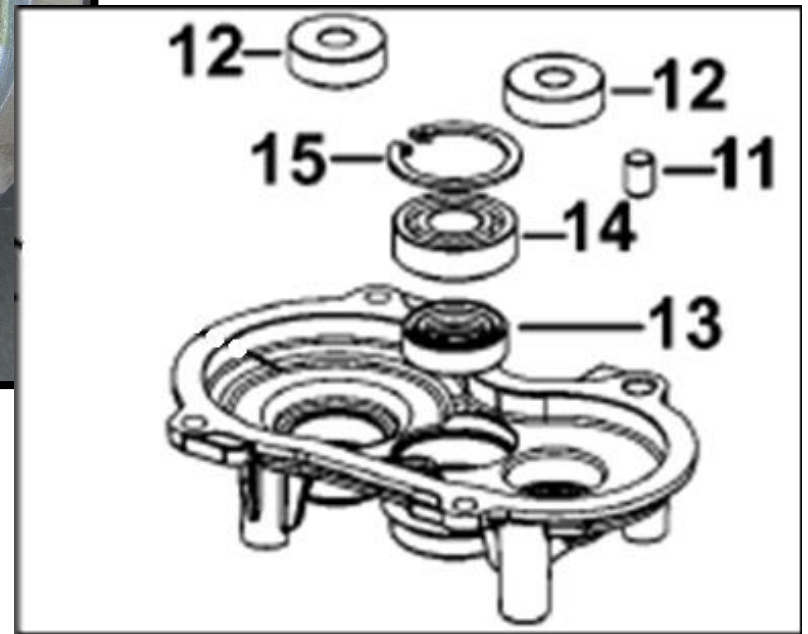
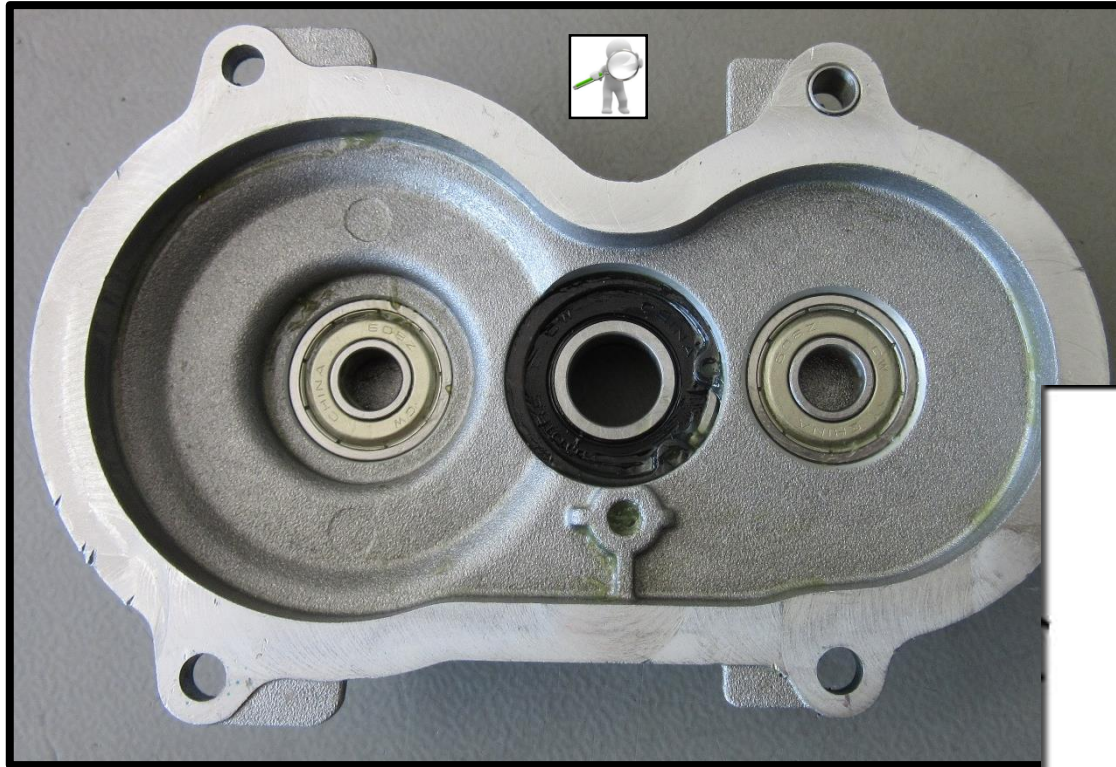

Very important information

Do not exchange the module without the magnet being checked first.

If the unit comes into the service and it will not work at all, or particularly it spins a quarter of a turn only, the four pole ferrite-magnet ring must be checked regarding the correct polarity.

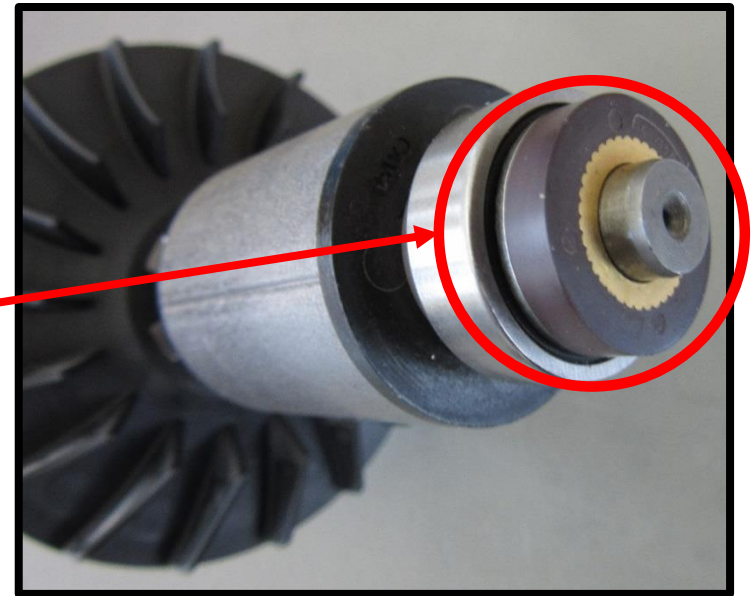

Note: Some flex Volt units are complete S/A – Other units have a separate rotor which is when this check needs to take place

Very important information

Detector foil makes magnetic fields visible



Use a detector foil to check the four single areas on the ferrite-magnet ring between the four red lines. If the picture shows a very clear border as shown below, the four pole ferrite-magnet ring will be ok. All four invisible boundaries must be checked.

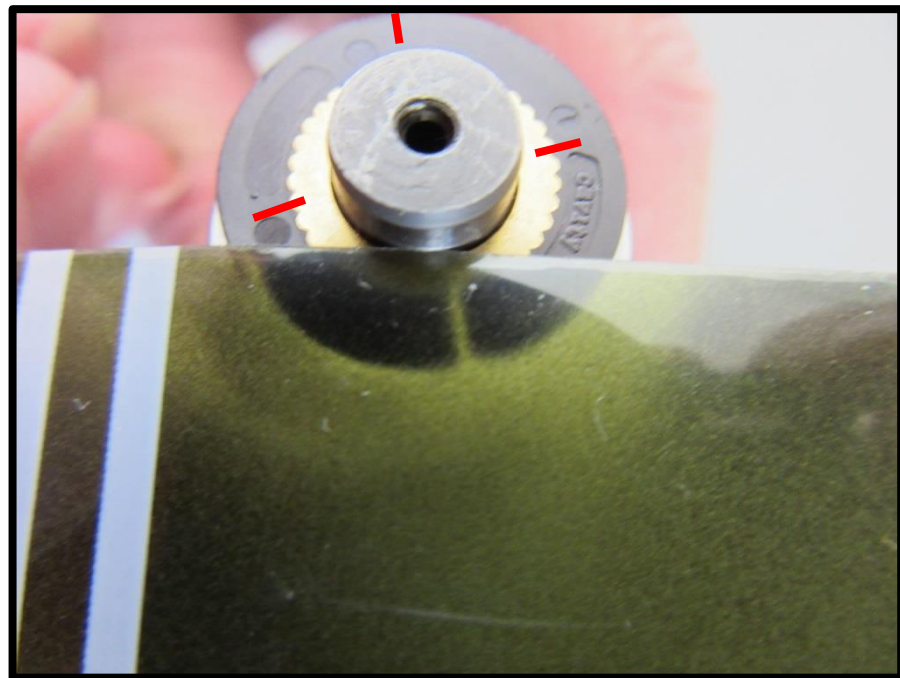

Very important information

If there is a line between the boundaries as shown below, a repolarization will have taken place, with the following consequences, the armature has been damaged and has to be replaced. It is mandatory that all areas of the four pole ferrite-magnet ring is checked for failure.

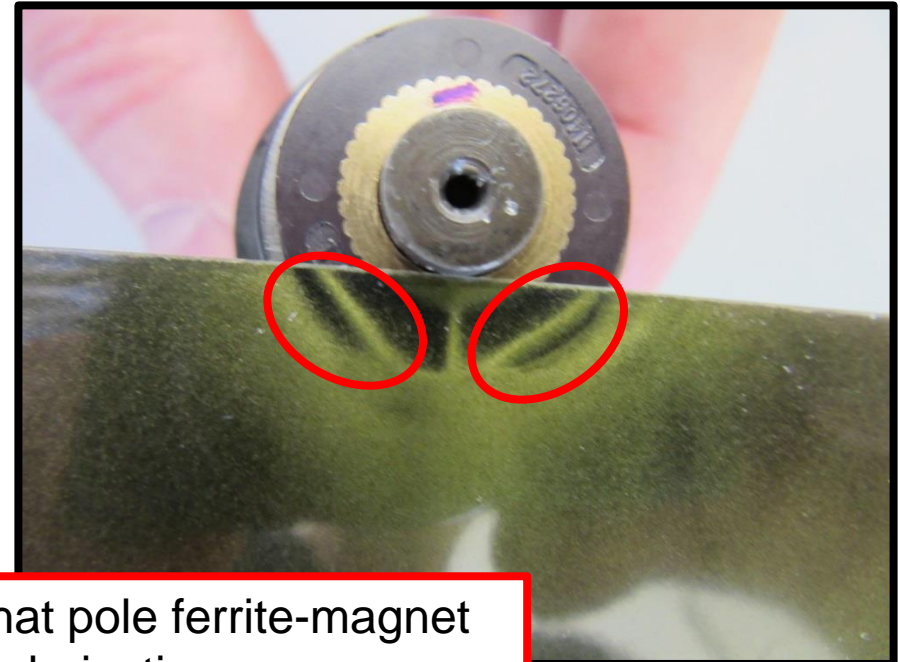
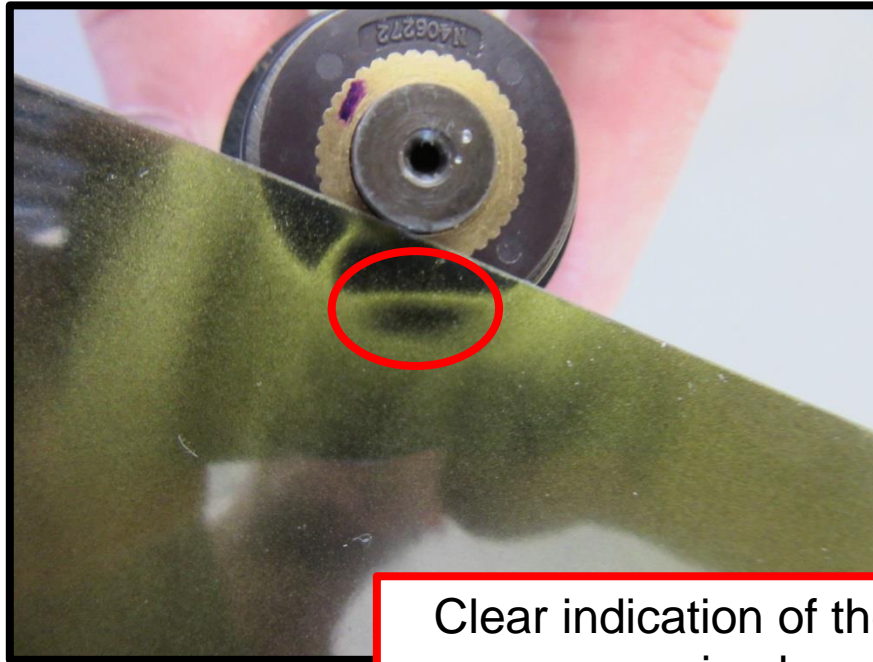

Clear indication of the that pole ferrite-magnet ring has repolarization



Lubrication

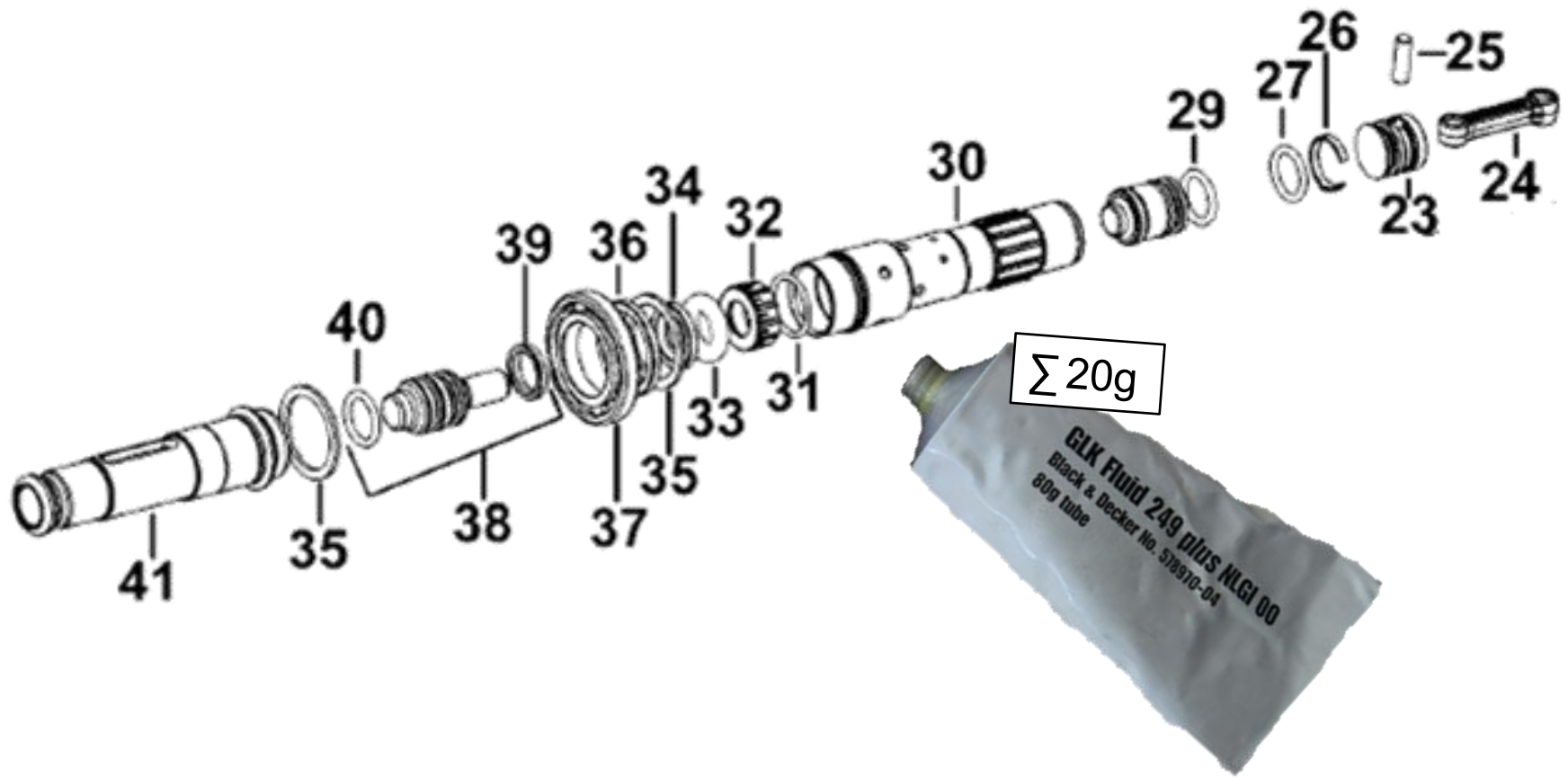

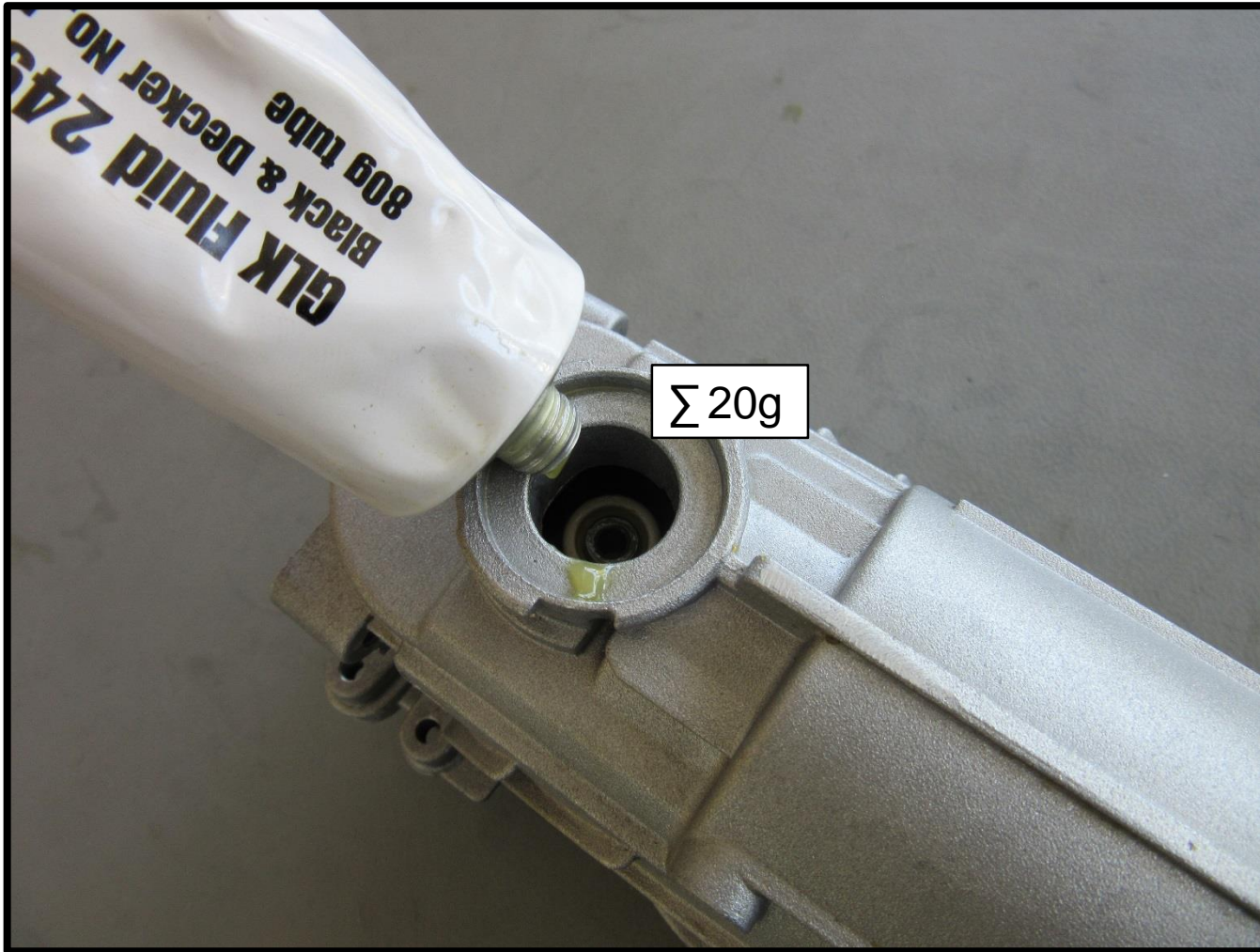

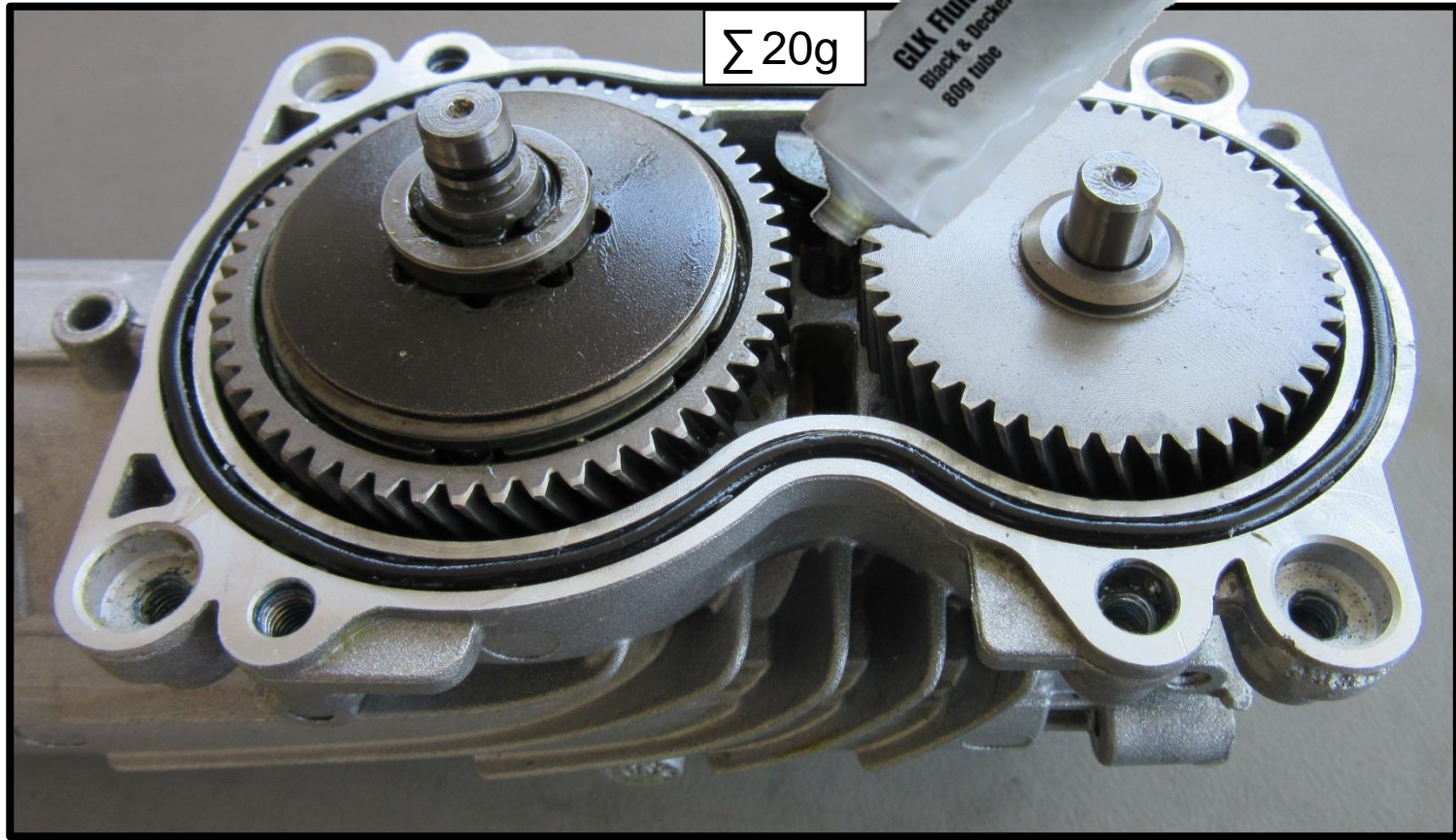

Σ 20g

GLK Fluid 249 plus HLG1 00
Black & Decker No. 378970-01
80g tube





Assembly Hints

Note:

Before assembled mode selector components, the spindle assembling has to be assembled first

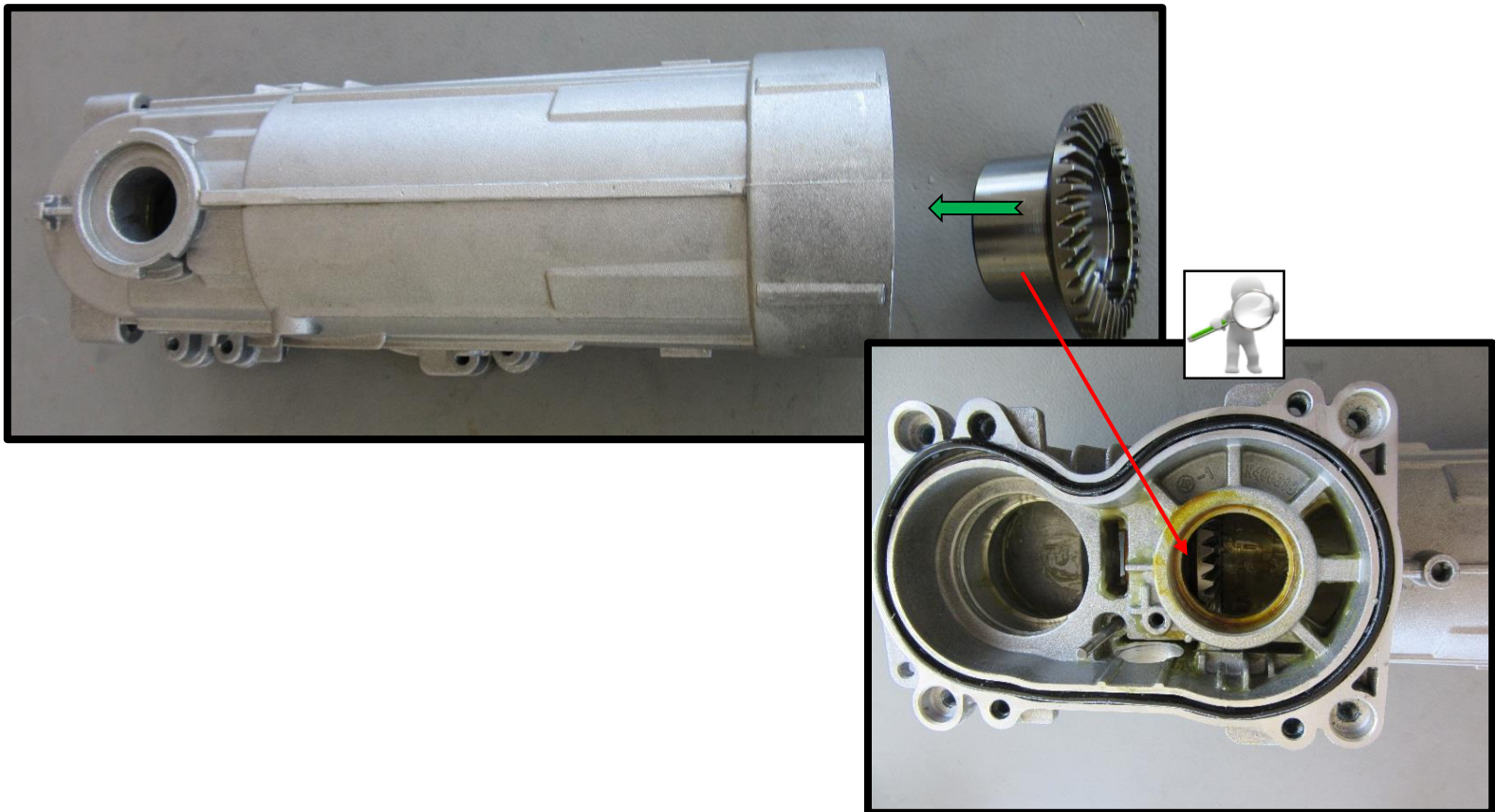

Assembling hints and tips

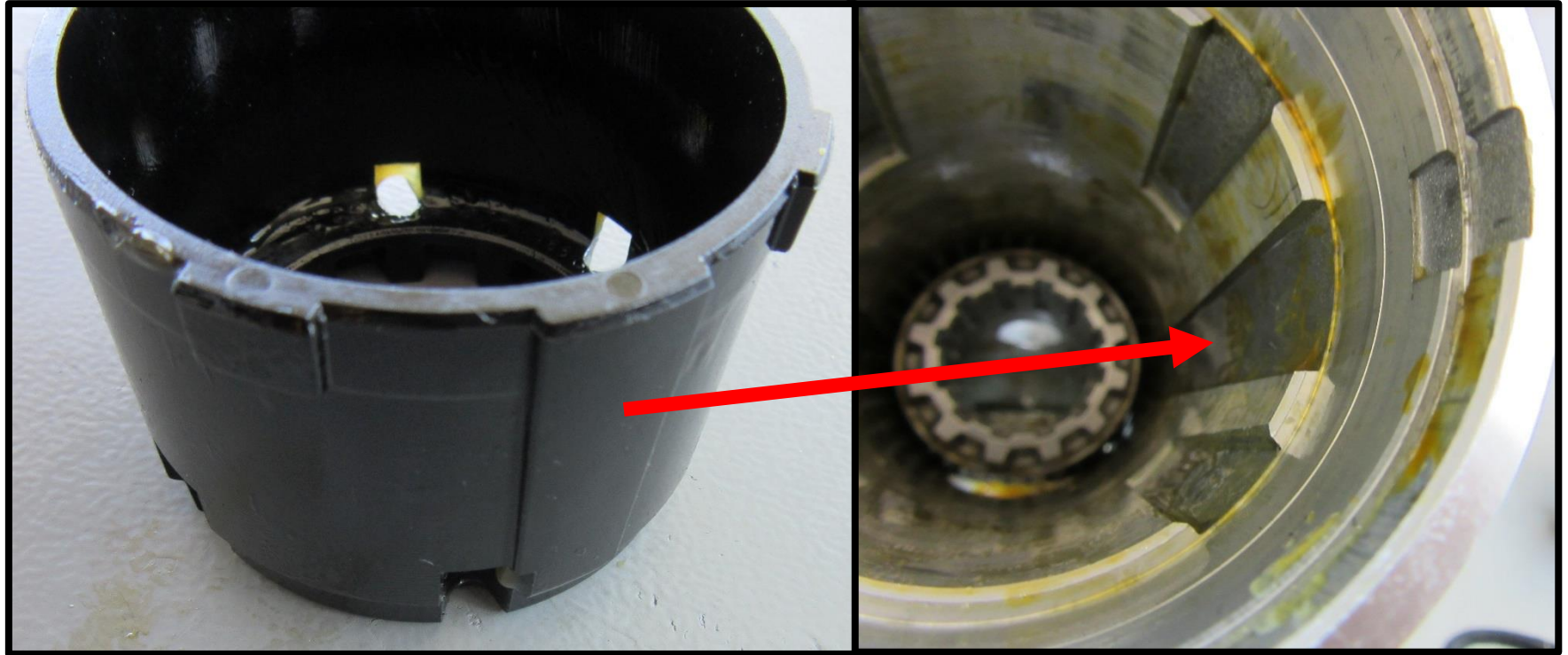

Assembling hints and tips

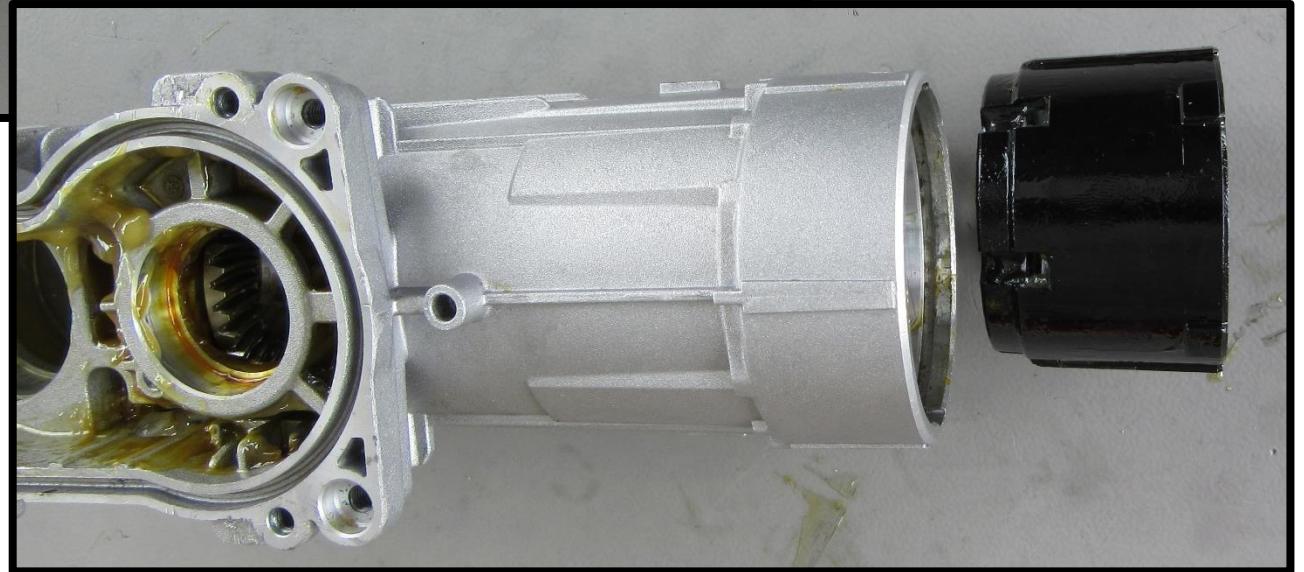
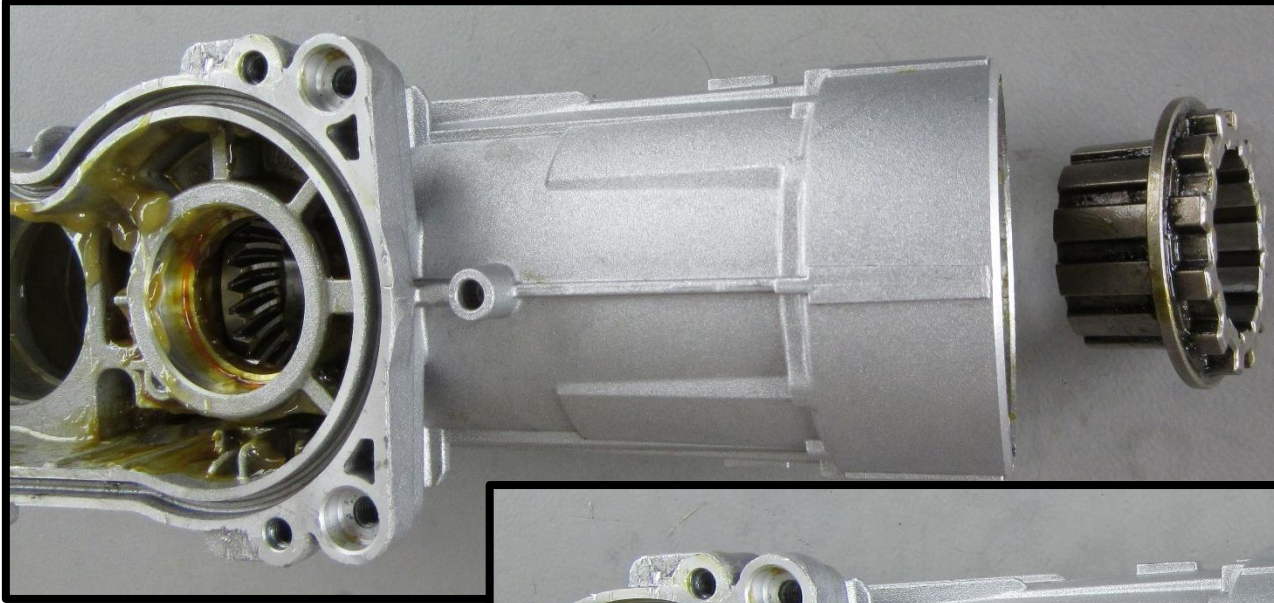

Assembling hints and tips

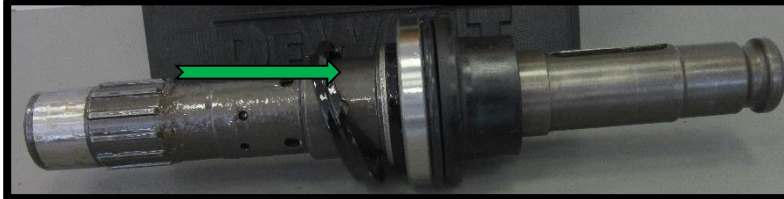

Assembling hints and tips

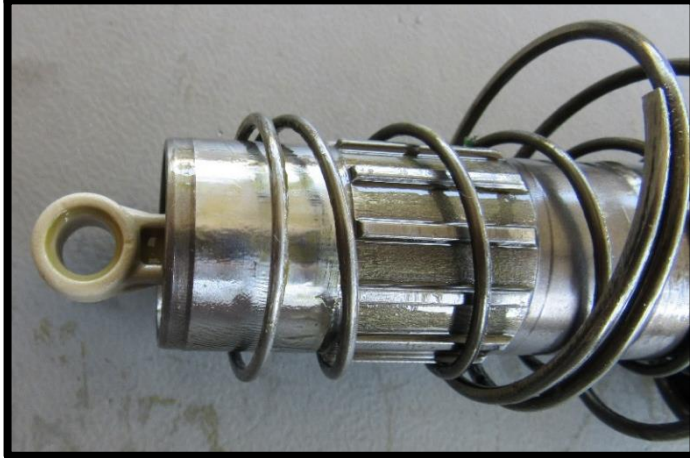

Assembling hints and tips

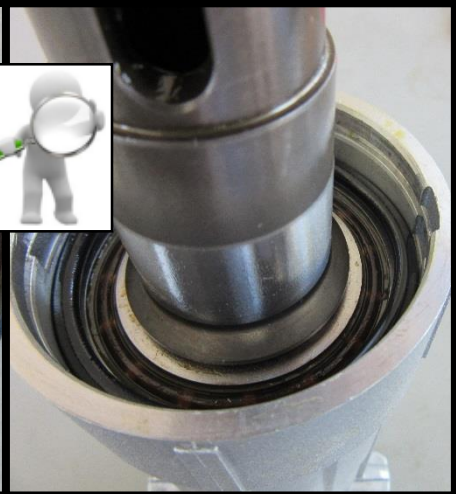
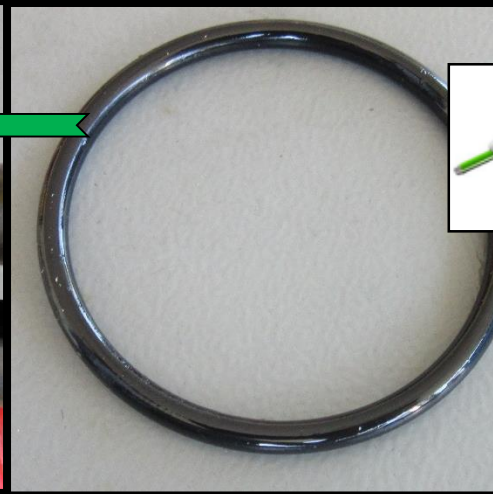
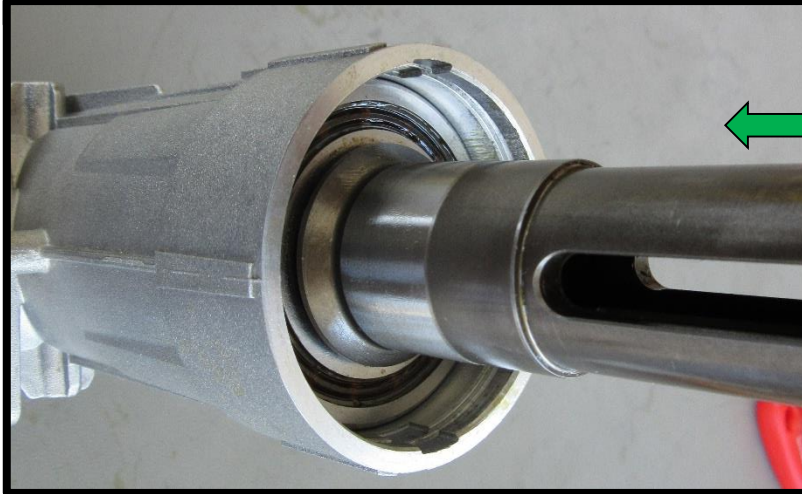
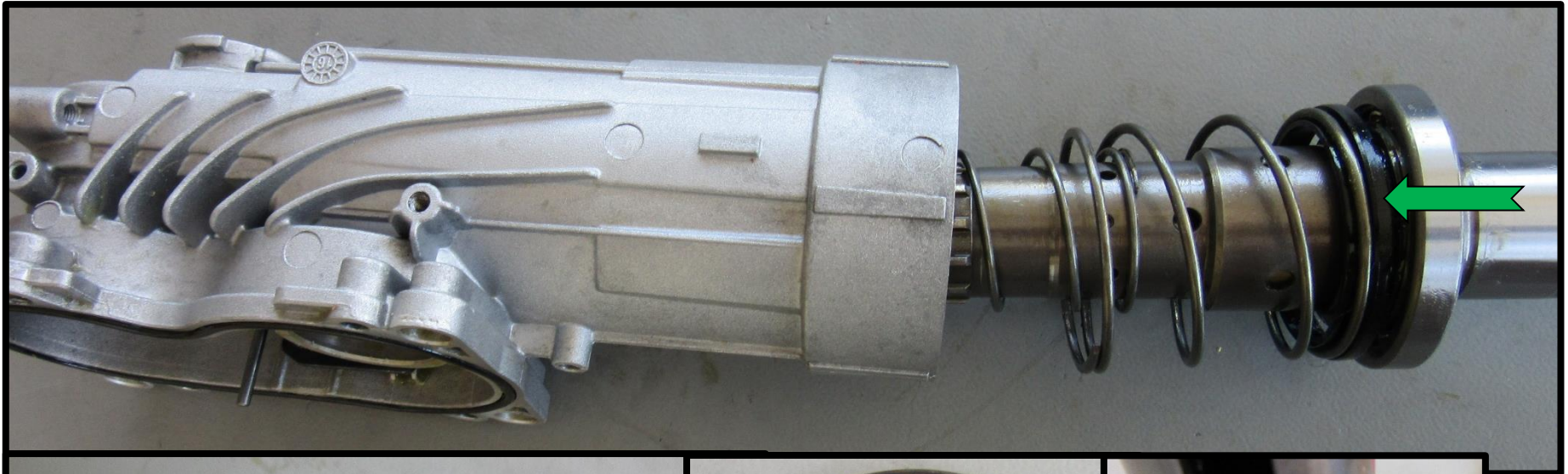

Assembling hints and tips

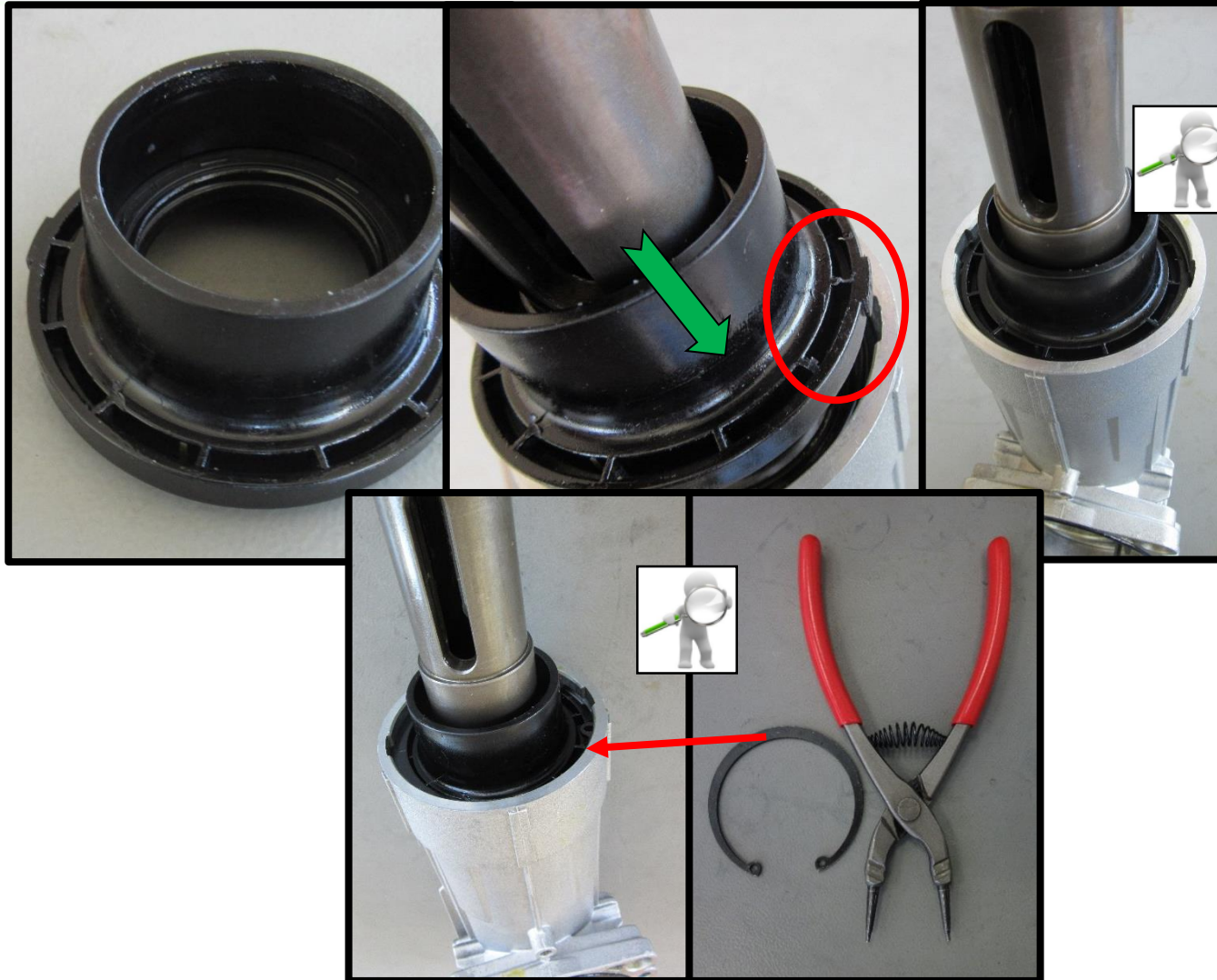

Assembling hints and tips

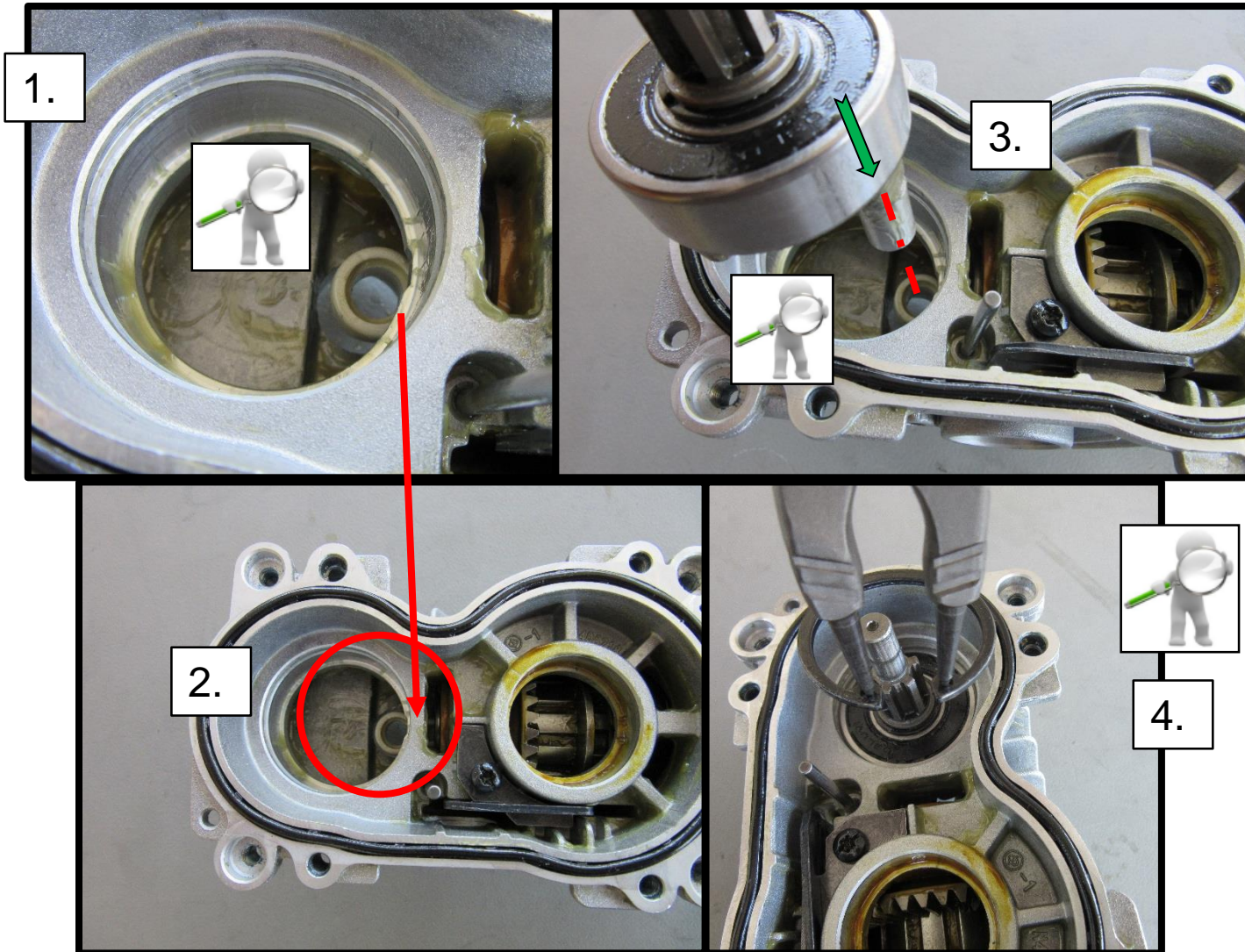

Assembling hints and tips

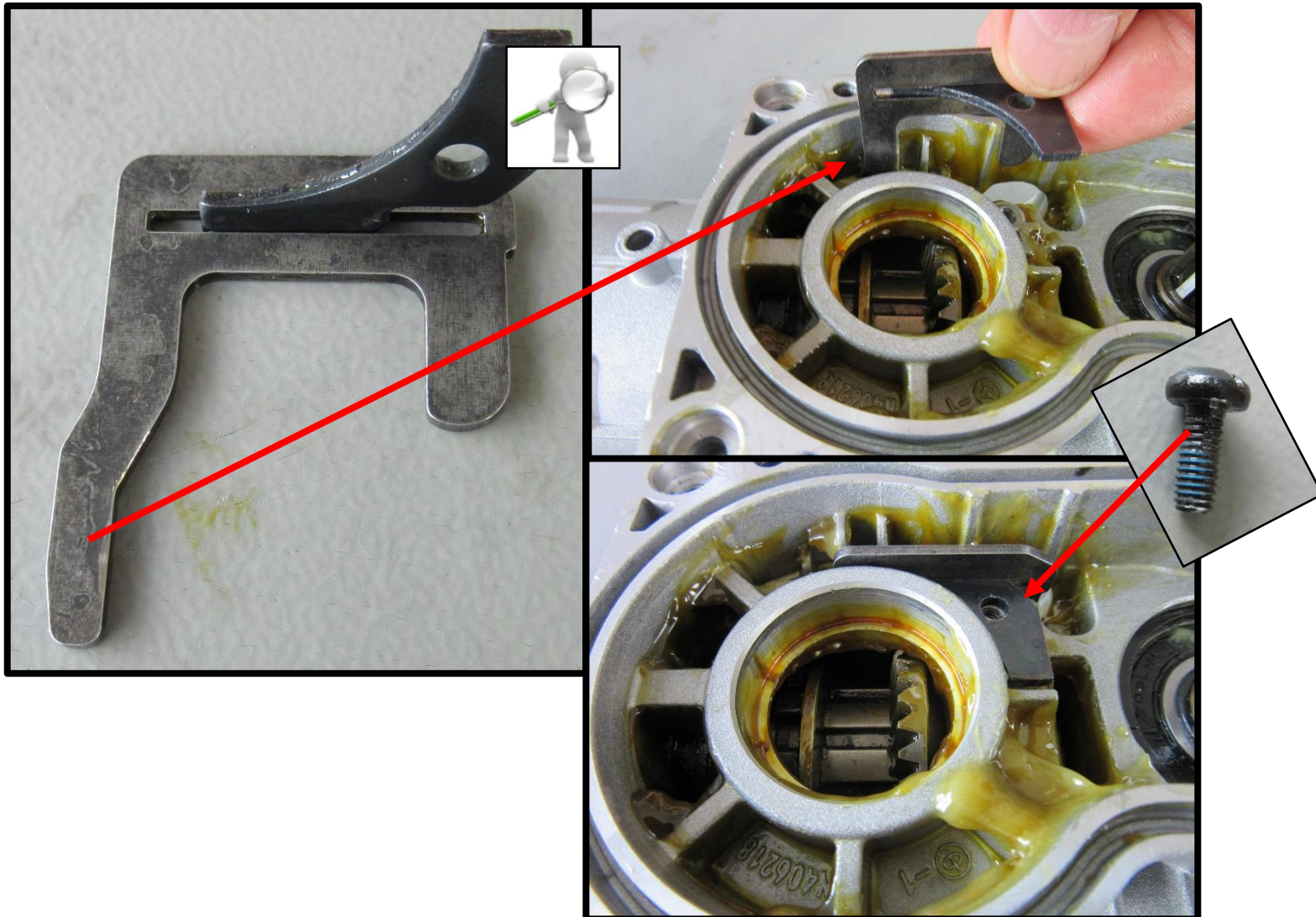

Assembling hints and tips

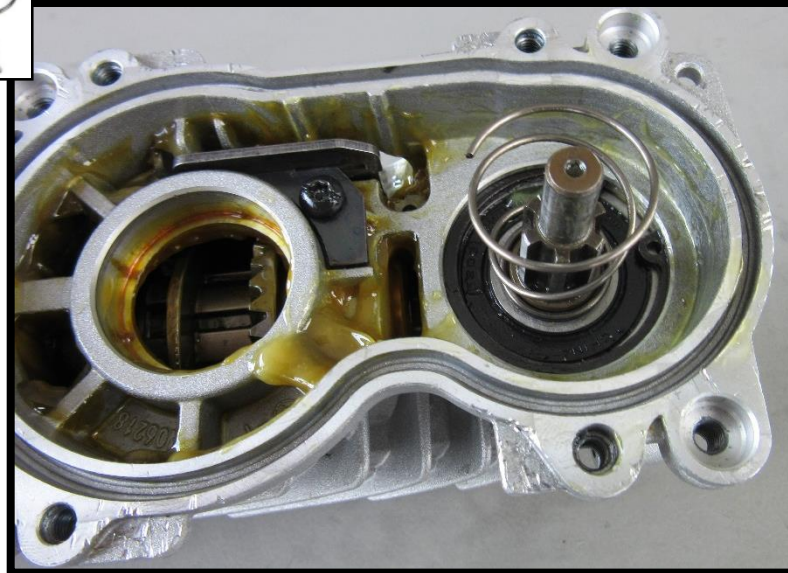
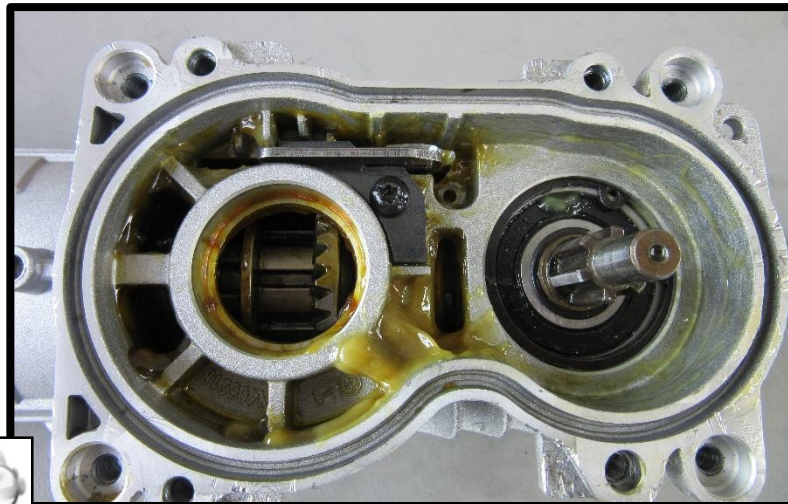

Assembling hints and tips

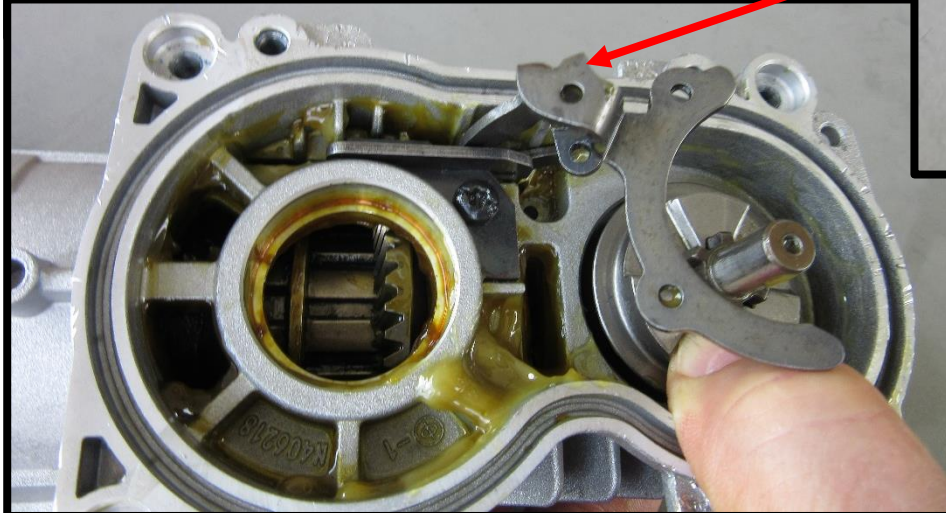
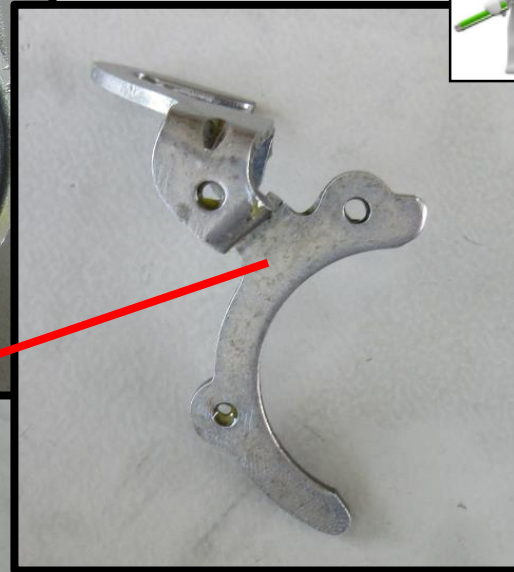
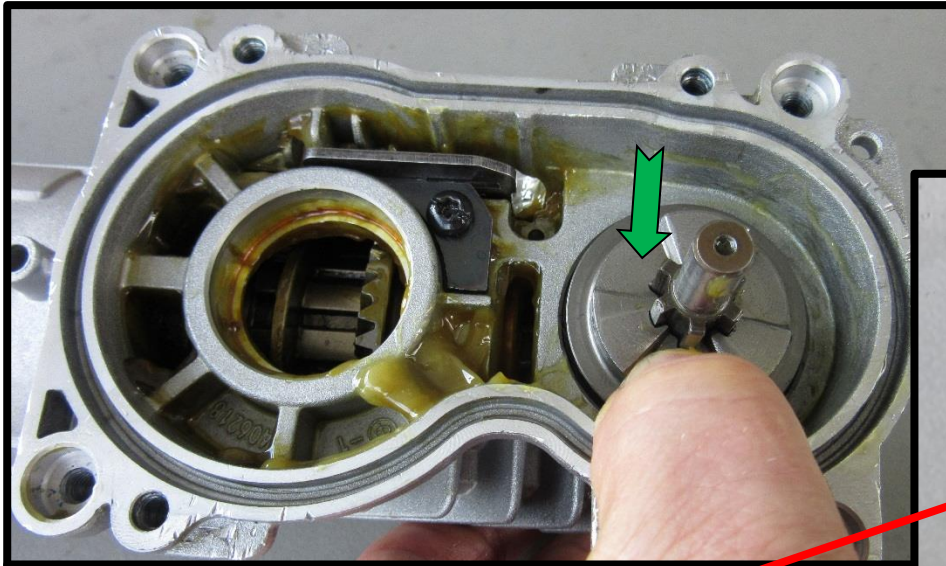

Assembling hints and tips

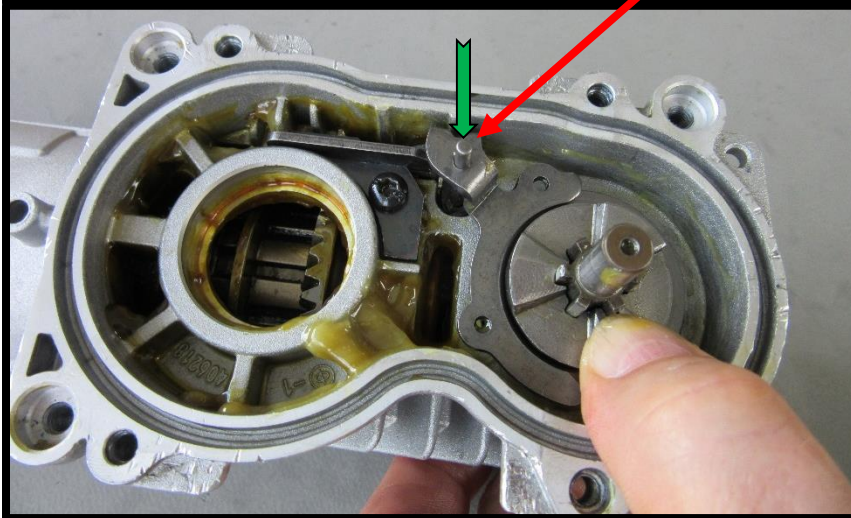
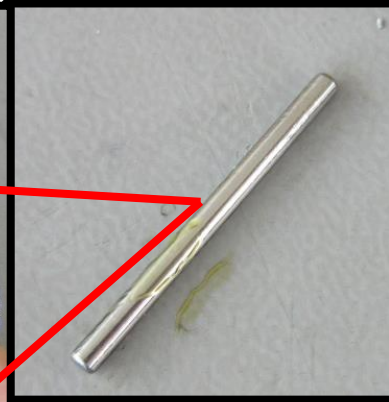
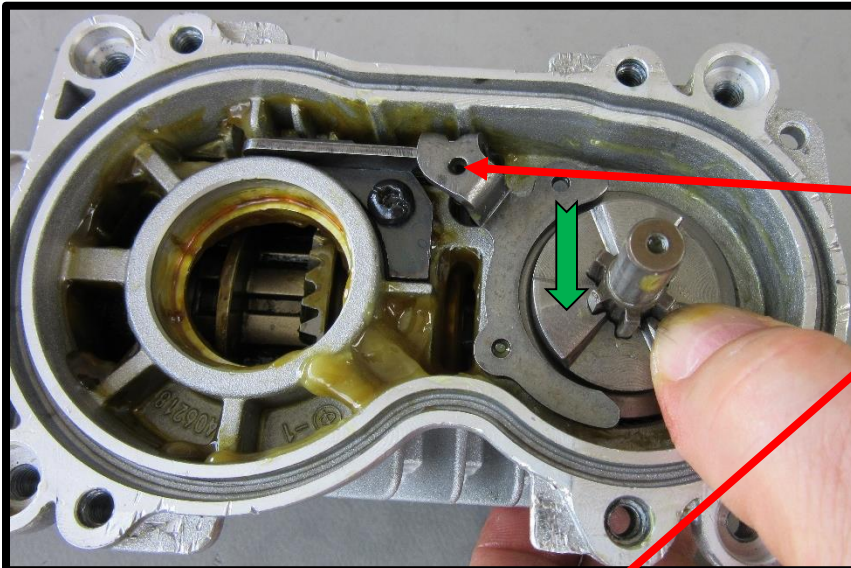

Assembling hints and tips

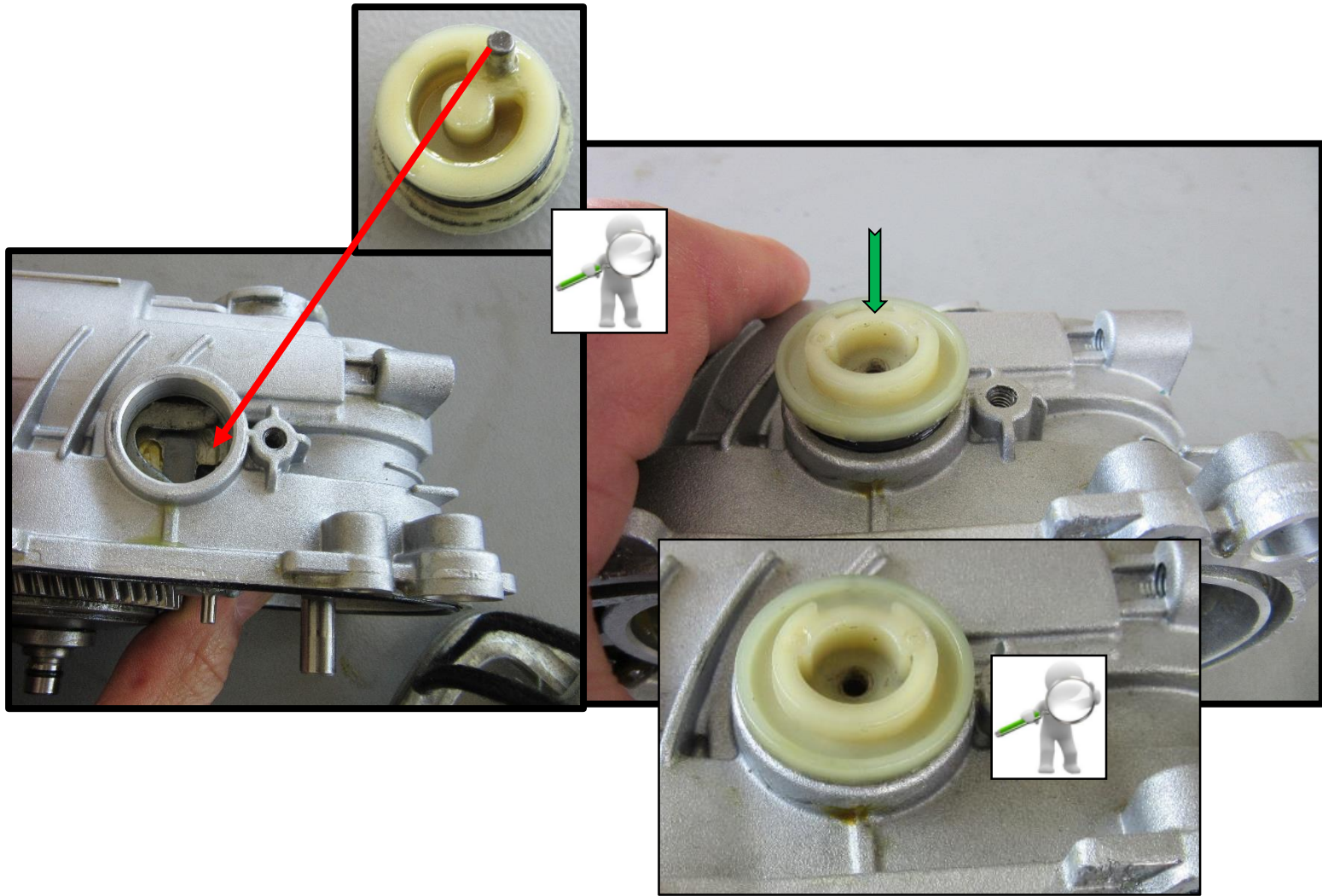

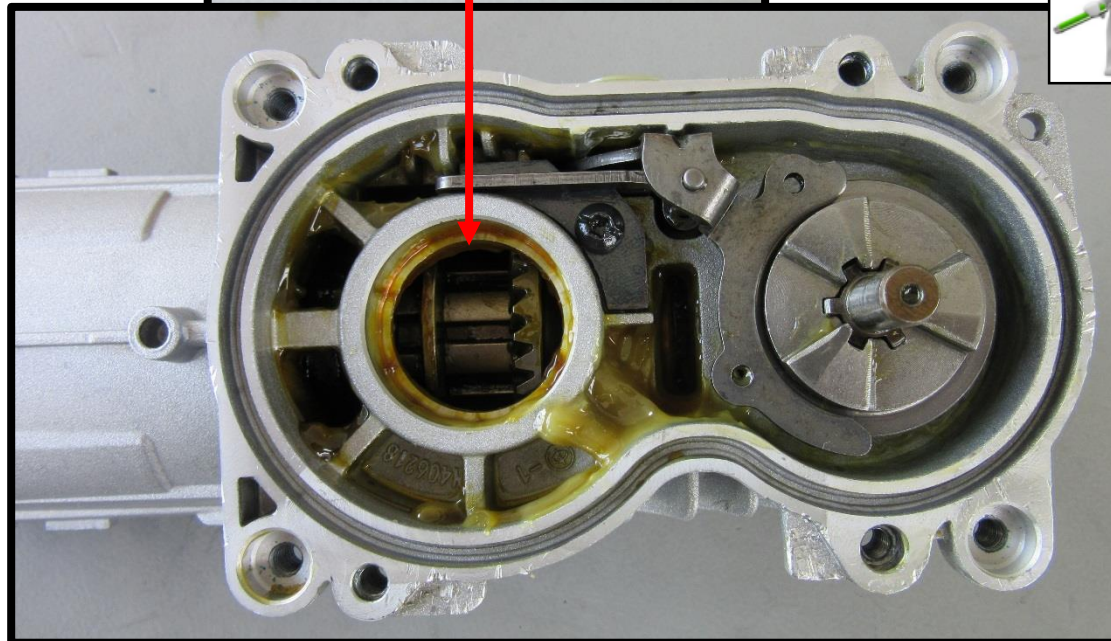
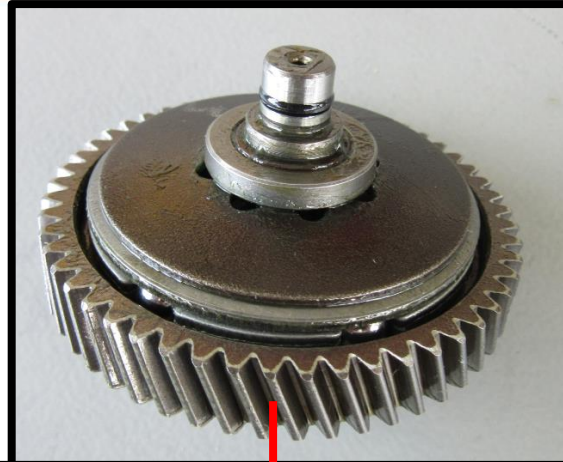

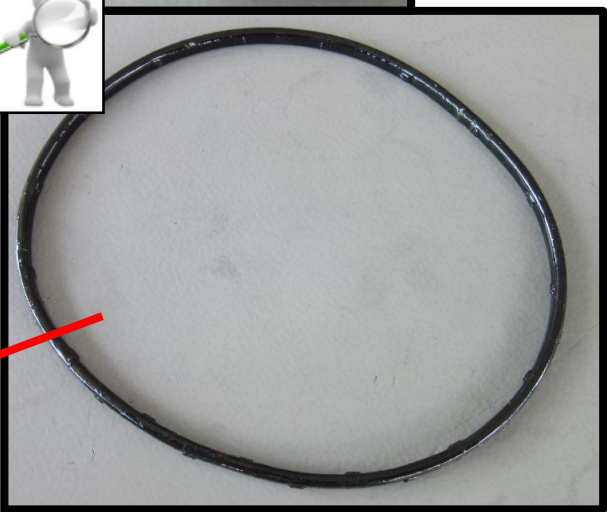
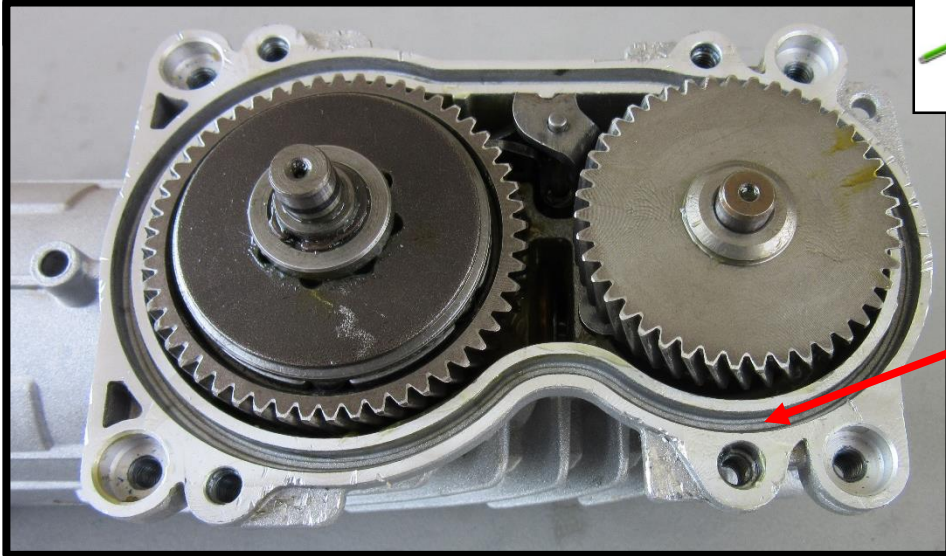
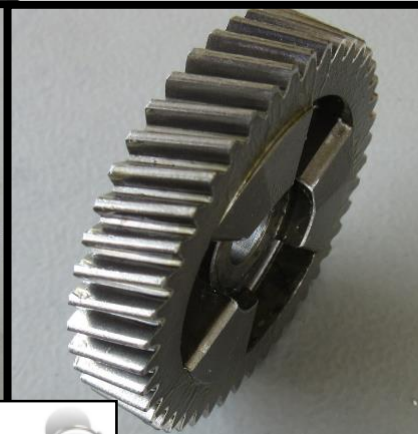
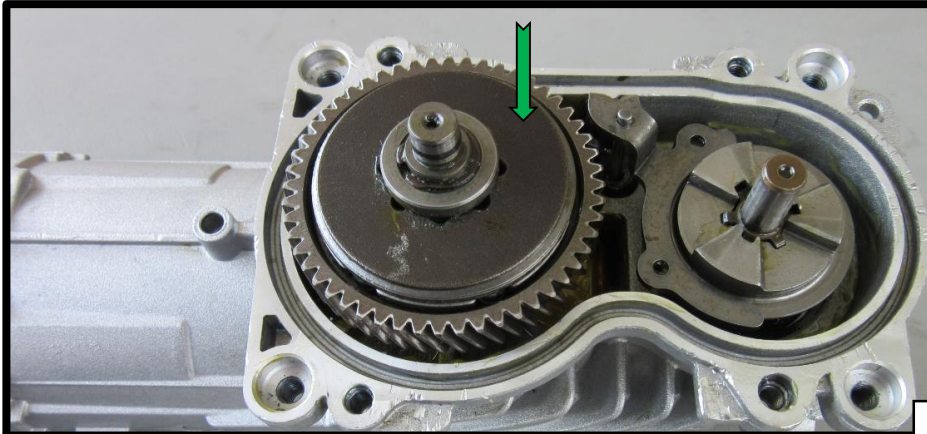

20g GLK

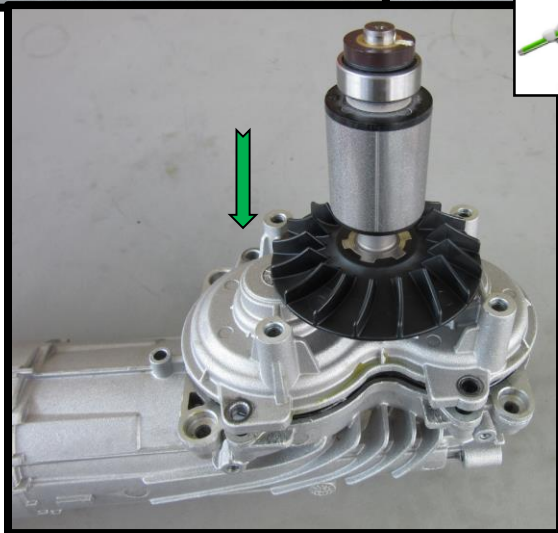
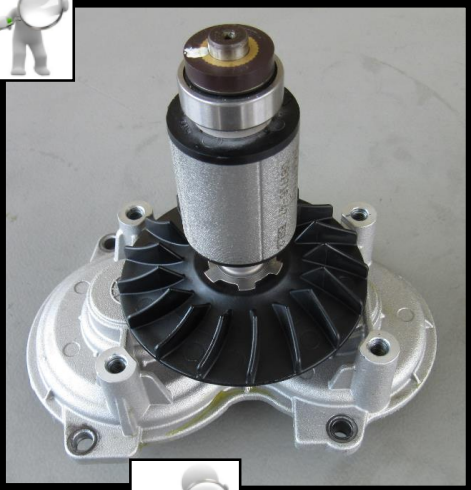
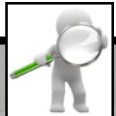
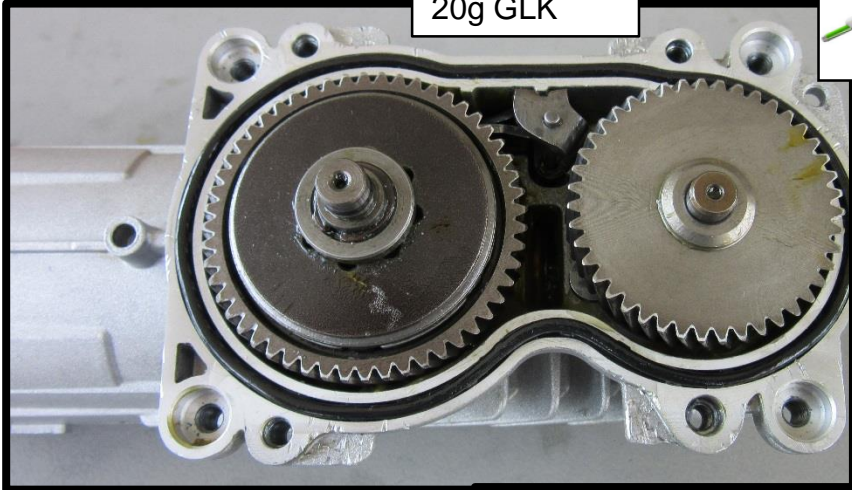

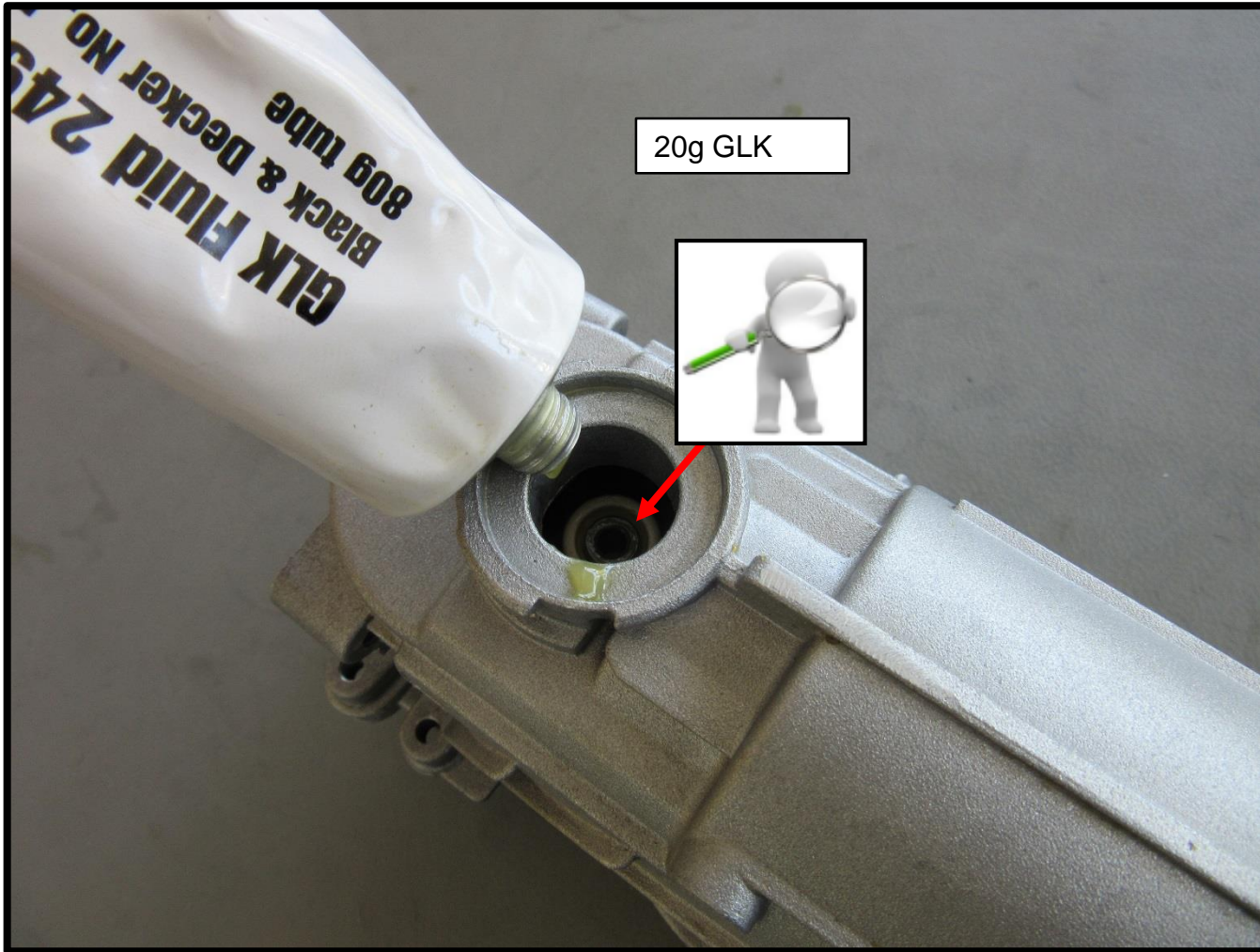

Functionally check

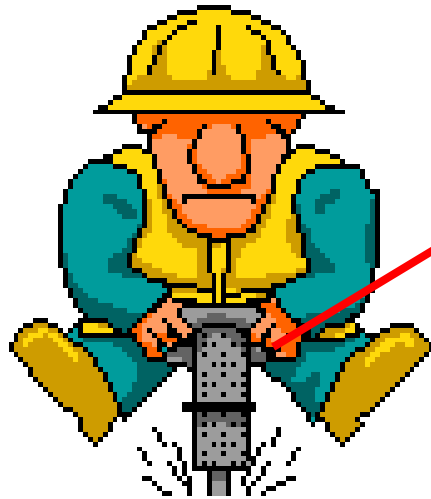

After repair



WWW.2HELPU.COM

-  Drawings
-  Parts List
-  Repair Instructions



Remember:
**the next check will be
made by your customer**

