

Go to **www.vtechphones.com**
to register your product for enhanced
warranty support and the latest VTech
product news.

DM1211
DM1211-2

Enhanced Range
Digital Audio Monitor



vtech[®]

User's manual

CONGRATULATIONS

on purchasing your new VTech product. Before using this product, please read **Important safety instructions**.

This manual has all the feature operations and troubleshooting necessary to install and operate your new VTech product. Please review this manual thoroughly to ensure proper installation and operation of this innovative and feature-rich VTech product.

For support, shopping, and everything new at VTech, visit our website at **www.vtechphones.com**.



WHAT'S IN THE BOX

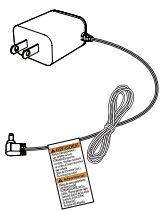
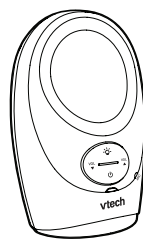
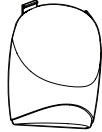
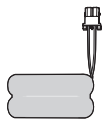

1 set for DM1211;
2 sets for DM1211-2

1 CONNECT AND CHARGE THE BATTERY

Install the parent unit battery

The parent unit runs on rechargeable battery or AC power. To continuously monitor your baby, make sure you use both battery and AC power at the same time. With the battery alone, the parent unit can cordlessly run for a short time only.

NOTES

- Use only the battery supplied with this product.
- If the parent unit will not be used for a long time, disconnect and remove the battery to prevent possible leakage.

1

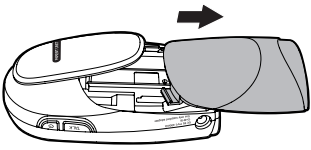

2

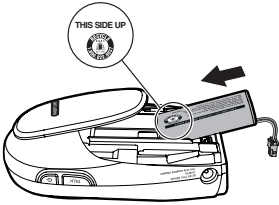

NOTE

Make sure the label **THIS SIDE UP** is facing up while inserting the battery.

3

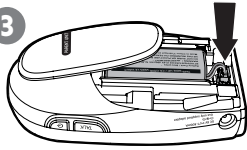

4

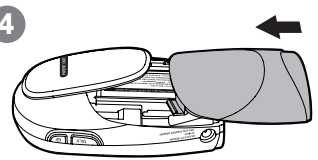

Replace the battery

To replace the battery, unplug the battery connector from the socket, and then pull the battery out of the battery compartment. Follow the steps above to install the battery.

Connect the baby monitor

When you have connected and turned on the baby unit and all the parent units, they will enter pairing mode automatically. It takes around 10 minutes for the pairing process to complete. When the parent unit and baby unit are successfully paired, both their power LEDs are on steadily. The baby monitor is ready to use.

NOTES

- Use only the power adapters supplied with this product.
- Make sure the baby monitor is not connected to a switch-controlled electric outlet.
- Connect the power adapters in a vertical or floor mount position only. The adapters' prongs are not designed to hold the weight of baby monitor, so do not connect them to any ceiling, under-the-table, or cabinet outlets. Otherwise, the adapters may not properly connect to the outlets.
- Make sure the parent unit, the baby unit and the power adapter cords are out of reach of children.
- With audio reminder feature preset to **ON**, the parent unit plays an audio reminder when it is connected to a baby unit.

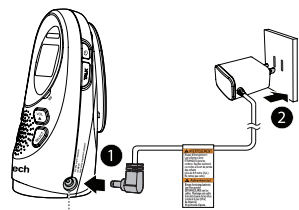
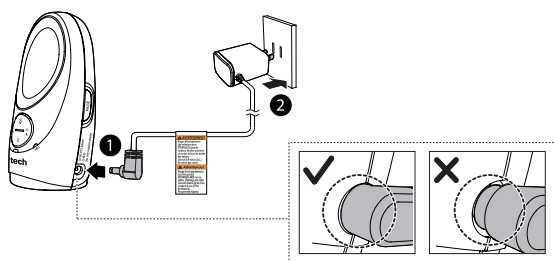

Charge the parent unit battery

When you have connected the parent unit and installed its battery for the first time or after power outage, the parent unit powers on automatically. The battery icon indicates the battery status (see the following table).

NOTES

- The parent unit battery is fully charged after 3 hours of continuous charging.
- It takes longer to charge the battery when the parent unit is turned on. To shorten the charging time, turn the parent unit off while charging.
- The standby time varies depending on the sensitivity level you set, your actual use and the age of the battery.

BATTERY INDICATORS	BATTERY STATUS	ACTION
The battery icon is off.	No battery is installed but operates using AC power.	Install the parent unit battery. Charge without interruption (at least 30 minutes).
The screen displays LOW BATTERY and . The light flashes.	The battery has very little charge and may be used for only a short time.	Charge without interruption (about 30 minutes).
The battery icon becomes solid .	The battery is fully charged.	To keep the battery charged, connect it to AC power when not in use.

2 BEFORE USE

NOTE

- This baby monitor is intended as an aid. It is not a substitute for proper adult supervision, and should not be used as such.

Test your audio monitor

You may test the baby monitor before initial use, and at regular times thereafter.

CAUTION

- For hearing protection, make sure the parent unit is more than 6.5 feet (2 meters) away from the baby unit. If you hear any high-pitched noise, move the parent unit further until the noise stops. You can also press ∇ VOL on the parent unit to lower or mute the noise.

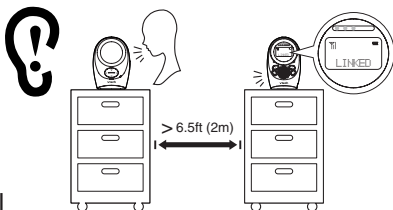

1. Make sure your baby unit and parent unit are on.
2. Speak towards the microphone of the baby unit. You will hear the sound at the parent unit, and see the visual sound indicators light up.

NOTE

- When the parent unit displays **NOT LINKED** and Υ flashes, move the parent unit closer to the baby unit (observe the minimum distance of 6.5 feet/ 2 meters). You can also check if the baby monitor is connected to a live power socket and switched on.

TIP

- Increase the speaker volume of the parent unit if you cannot hear the sounds transmitted from the baby unit.

Positioning the baby monitor

CAUTION

- Keep the baby units out of the reach of your baby. Never place or mount the baby units inside the baby's crib or playpen.

1. Place the baby units more than 3 feet (1 meter) away from your baby.
2. Place the parent unit more than 6.5 feet (2 meters) away from the baby unit to avoid screeching noise.

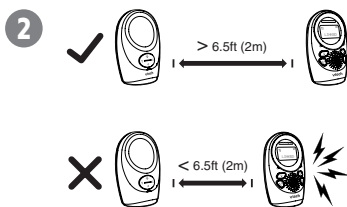
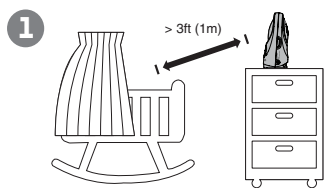

CAUTION

- The default volume of your parent unit is level 3. If you experience high-pitched screeching noise from your baby monitor while positioning:
 - Make sure your baby unit and parent unit are more than 6.5 feet (2 meters) apart, OR
 - Turn down the volume of your parent unit.

Operating range

The operating range of the baby monitor is up to 1,500 feet (450 meters) outdoors or 160 feet (50 meters) indoors. The actual operating range may vary depending on the environmental conditions, and other interferences such as walls, doors, and other obstructions.

3 USING THE BABY MONITOR

Power on or off the baby unit

- Press ⏻ to power on the baby unit. The power light turns on.
- Press and hold ⏻ to power off the baby unit. The power light turns off.

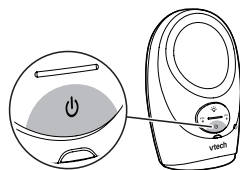

Power on or off the parent unit

- Press and hold ⏻ to power on the parent unit. The screen turns on.
- Press and hold ⏻ again to power off the parent unit. The screen turns off.

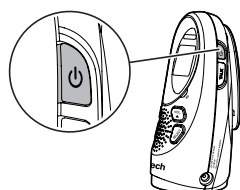

NOTE

- The parent unit powers on automatically once it is connected to power socket or battery installed. The baby unit also powers on automatically once connected to power socket.

Adjust the speaker volume for baby unit

- Press ∇ VOL or ∇ VOL on the baby unit at any time.

NOTE

- The speaker of baby unit cannot be muted.

Adjust the speaker volume for parent unit

You can adjust the speaker volume from **VOLUME 1** to **VOLUME 5**, or turn it off. The speaker volume is preset to **VOLUME 3**.

- Press ∇ VOL or ∇ VOL when the parent unit is not in use.

When the speaker volume is set to **VOLUME OFF**, the screen displays 🔇 .

3 USING THE BABY MONITOR (CON'T)

Adjust the sound sensitivity of the baby unit

You can choose to hear sounds from the baby unit all the time, or to hear sounds that exceed a certain level. You can use the parent unit to adjust the microphone sensitivity of your baby unit. The higher the sensitivity level, the more sensitive the baby unit is in detecting sounds for transmitting to the parent unit. The VOX sensitivity level is preset to **HIGHEST**.

VOX SENSITIVITY LEVEL	Highest	High	Medium	Low	Lowest
DESCRIPTION	The parent unit speaker is constantly on, and you will hear all sounds (including background noises) from your baby's room.	The parent unit speaker turns on for soft babbling and louder sounds from your baby. It remains quiet when your baby sleeps soundly.	The parent unit speaker turns on for loud babbling and louder sounds from your baby. It remains quiet when your baby makes soft sounds.	The parent unit speaker turns on for crying and louder sounds from your baby. It remains quiet when your baby makes soft sounds.	The parent unit speaker turns on for loud crying or screeching sounds from your baby. It remains quiet when your baby makes soft sounds.

1. Press when the parent unit is not in use.
2. Press **SELECT** to select **VOX LEVEL**.
3. Press or to choose the desired sensitivity level.
4. Press **SELECT** to confirm your selection. The screen displays **SAVED** and you hear a confirmation tone.

NOTE

- To enter the **VOX Level** menu of the parent unit, the baby unit must be turned on.

Sound alert

If you want the parent unit alerts you with sound, especially when the baby unit detects loud sounds, you can turn on the sound alert feature. This feature is preset to **OFF**.

Once this feature is on, is shown on LCD display. When the visual sound indicator hits the red light range, i.e. the baby unit detects loud sounds, your parent unit beeps and flashes.

1. Press when the parent unit is not in use.
2. Press or to choose **SOUND ALERT**, then press **SELECT**.
3. Press or to choose **ON** or **OFF**.
4. Press **SELECT** to confirm your selection. The screen displays **SAVED** and you hear a confirmation tone.

NOTE

- The sound alert setting on each parent unit is independent.

Vibration alert

You can set your parent unit to vibrate and alert you, whenever the baby unit detects loud sounds. This feature is preset to **OFF**.

Once this feature is on, is shown on LCD display. When the visual sound indicator hits the red light range, i.e. the baby unit detects loud sounds, your parent unit vibrates and flashes.

1. Press when the parent unit is not in use.
2. Press or to choose **VIBE ALERT**, then press **SELECT**.
3. Press or to choose **ON** or **OFF**.
4. Press **SELECT** to confirm your selection. The screen displays **SAVED** and you hear a confirmation tone.

NOTES

- Each time you set the vibration alert to **ON**, the parent unit vibrates briefly after you press **SELECT**.
- The vibration alert setting on each parent unit is independent.

Nightlight

Both your parent unit(s) and baby unit allow you to turn on or off the nightlight on the baby unit.

Turn on/off the nightlight using the baby unit:

1. Press to turn on the nightlight.
2. Press again to turn off the nightlight.

Turn on/off the nightlight using the parent unit:

1. Press when the parent unit is not in use.
2. Press or to choose **NIGHTLIGHT**, then press **SELECT**.
3. Press or to choose **ON** or **OFF**.
4. Press **SELECT** to confirm your selection. The screen displays **SAVED** and you hear a confirmation tone.

NOTES

- When the nightlight is turned on, the parent unit displays .
- The nightlight on baby unit operates even when the parent unit battery is out of charge or has been turned off.
- If the parent unit lost link, the nightlight icon on its LCD display will disappear, regardless of the nightlight status.

Language

You can select a language (**English, Spanish or French**) to be used in all screen displays. The language is preset to **English**.

1. Press when the parent unit is not in use.
2. Press or to choose **LANGUAGE**, then press **SELECT**.
3. Press or to choose **ENGLISH, ESPANOL, or FRANCAIS**.
4. Press **SELECT** to confirm your selection. The screen displays **SAVED** and you hear a confirmation tone.

NOTE

- The language setting on each parent unit is independent.

Turn on or off the audio reminder

With audio reminder feature preset to **ON**, the parent unit plays an audio reminder when it is connected to a baby unit. It reminds you to place the baby unit at least 3 feet (1 meter) away from your baby, and keep the cords out of the reach of children.

1. Press when the parent unit is not in use.
2. Press or to choose **REMINDER**, then press **SELECT**.
3. Press or to choose **ON** or **OFF**.
4. Press **SELECT** to confirm your selection, and you hear a confirmation tone.

NOTES

- You can press or to adjust the volume when the parent unit is playing the reminder.
- If the speaker volume of the parent unit is turned off, it will change to the default volume level when the parent unit plays the reminder.

Set default

Use this feature to restore to the default settings. Restoring the default settings on one parent unit will also reset the shared settings for VOX sensitivity level of the other parent unit.

1. Press when the parent unit is not in use.
2. Press or to choose **SET DEFAULT**, then press **SELECT**.
3. Press or to choose **YES** or **NO**.
4. When you choose **YES**, press **SELECT** to confirm your selection. The screen displays **SAVED** and you hear a confirmation tone.

-OR-

When you choose **NO**, press **SELECT** to confirm your selection. The screen displays the previous menu.

Talk to the baby unit

You can broadcast messages from a parent unit to the baby unit and the other parent unit. If you have two parent units, you can use both of them at the same time to talk to the baby unit.

1. Press and hold **TALK** on the side of the parent unit. The screen displays **TALK** when the voice connection to the baby unit is made.
2. Speak towards the **MIC** on the parent unit. Your voice is broadcast to the baby unit and the other parent unit.

NOTES

- If you have two parent units, and you use one of them to talk to you baby, your voice will broadcast to both the baby unit and the other parent unit. The other parent unit displays **TALKBACK**. However, no sound will transmit from the baby unit to any parent unit during broadcasting.
- If speaker volume of the parent unit has been turned off before the talk, it will change to default volume level after the talk finished.

Find/page the parent unit

Use this feature to locate misplaced parent units.

1. Press **PAGE** on the baby unit. All idle parent units ring and display **PAGING**.
2. To end paging, press any key on the parent unit, or press **PAGE** on the baby unit.

NOTES

- Paging rings all parent units even if the speaker volume of parent unit is set to **VOLUME OFF**.
- The baby unit cannot page any parent unit that is turned off, out of range, or talking to the baby unit.

TECHNICAL SPECIFICATIONS

Frequency control	Crystal controlled PLL synthesizer
Transmit frequency	Baby unit: 1921.536-1928.448 MHz Parent unit: 1921.536-1928.448 MHz
Channels	5
LCD	35 (x) x 21.2 (y) mm B&W LCD
Nominal effective range	Maximum power allowed by FCC and IC. Actual operating range may vary according to environmental conditions at the time of use.
Power requirement	Parent unit: 2.4 V Ni-MH battery Baby unit power adapter: Output: 6V DC 400mA Parent unit power adapter: Output: 6V DC 400mA



BABY UNIT OVERVIEW

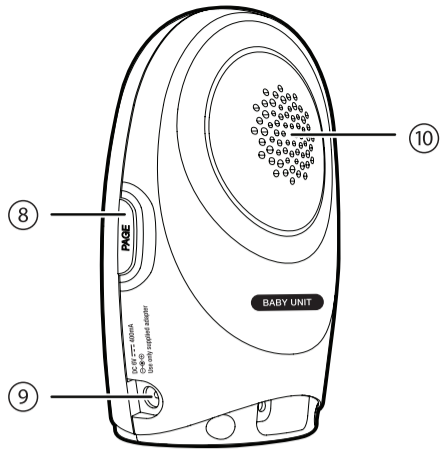
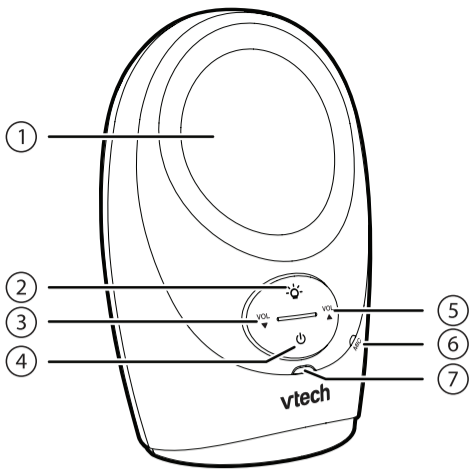

1 Night light

- On when night light is turned on manually.
- Off when night light is turned off manually.

2

- Press to turn the night light on or off.

3 VOL



- Press to decrease the speaker volume.

4 (On/off)

- Press to power on, and the power light turns on.
- Press and hold to power off, and the power light turns off.

5 VOL



- Press to increase the speaker volume.

6 Microphone

7 Power light

- On when the baby unit is turned on.

8 PAGE

- Press to start or stop paging parent unit.

9 Power jack

10 Speaker



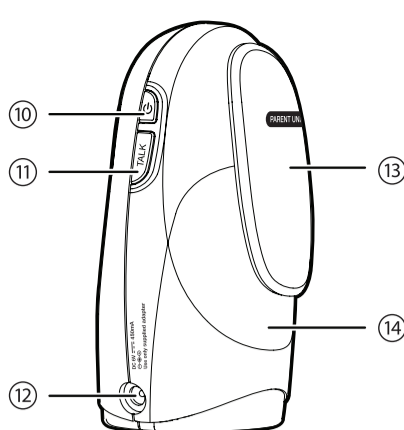
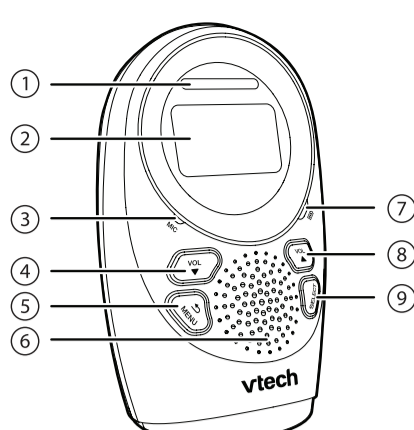

PARENT UNIT OVERVIEW



1 Visual sound indicator



The visual sound indicator shows the sound level detected by the baby unit.

-  One to three green lights indicate a moderate sound level detected by the baby unit.
-  Additional red lights indicate a higher sound level detected by the baby unit (e.g. baby crying loudly).

2 LCD display

3 Microphone

4 VOL



- Press to decrease the speaker volume.
- Press repeatedly until the volume reaches the minimum to turn it off.
- While in a menu, press to scroll down.

5 MENU



- Press to enter the menu.
- While in a menu, press to return to the previous menu.

6 Speaker

7 Battery LED

- Light on when the battery is being charged.
- Light flashes when the battery is low and needs charging.
- Light off when the parent unit is running on AC power without battery installed, or the parent unit is running on battery only.

8 VOL



- Press to increase the speaker volume.
- While in a menu, press to scroll up.

9 SELECT

- While in a menu, press to choose an item, or save a setting.

10 (On/off)

- Press and hold to power on, the screen turns on.
- Press and hold again to power off, the screen turns off.
- While in a menu, press to return to idle screen.

11 TALK

- Press and hold to talk to the baby.

12 Power jack

13 Belt clip

14 Battery compartment cover



PARENT UNIT ICONS

Status icons



Connection status

- displays when strong signal strength is detected between the baby unit and the parent unit.
- displays when moderate signal strength is detected between the baby unit and the parent unit.
- displays when the weak signal strength is detected between the baby unit and the parent unit.
- flashes when the link between the baby unit and the parent unit is lost.



Night light

- On when the night light is turned on.



Sound alert

- Displays when the sound alert of the parent unit is turned on.
- Flashes when there are loud sounds detected from the baby unit.



Vibration alert

- Displays when the vibration alert of the parent unit is turned on.
- Flashes when there are loud sounds detected from the baby unit.



Volume off

- Displays when the parent unit speaker volume is turned off.



Battery status

- animates when the battery is charging.
- displays solid when the battery is fully charged.
- flashes when the battery is in low level and needs charging.
- No battery icon displays when there is no battery installed.

Parent unit display screen messages

LINKED

- The link between the parent unit and the baby unit is established.

LOW BATTERY

- The parent unit uses only the rechargeable battery pack and it needs to be recharged.

NOT LINKED

- The link between the parent unit and the baby unit is lost continuously for over 10 seconds.

PAGING

- Both idle parent units are being paged by the baby unit.

SAVED

- Your selection has been saved.

SEARCHING

- The parent unit is out of range of the baby unit, or the baby unit is out of power.

TALK

- You are using the parent unit to talk to your baby.

TALKBACK

- Someone is using the other parent unit to talk to the baby, and the voice is also broadcasting to your parent unit. No sound will transmit from the baby unit to any parent unit during broadcasting.
- For DM1211-2 only



GENERAL PRODUCT CARE

To keep this product working well and looking good, follow these guidelines:

- Avoid putting it near heating appliances and devices that generate electrical noise (for example, motors or fluorescent lamps).
- DO NOT expose it to direct sunlight or moisture.
- Avoid dropping the product or treating it roughly.
- Clean with a soft cloth.
- DO NOT immerse the parent unit and the baby unit in water and do not clean them under the tap.
- DO NOT use cleaning spray or liquid cleaners.
- Make sure the baby unit and parent unit are dry before you connect them to the mains again.

STORAGE

When you are not going to use the baby monitor for some time, remove the rechargeable battery from the parent unit. Store the parent unit, the baby unit and the adapters in a cool and dry place.

Q&A FREQUENTLY ASKED QUESTIONS

Below are the questions most frequently asked about the baby monitor. If you cannot find the answer to your question, visit our website at www.vtechphones.com or call **1 (800) 595-9511** for customer service.

Why does the baby monitor not respond normally?	Try the following (in the order listed) for common cure: <ol style="list-style-type: none"> 1. Disconnect the power to the baby unit and the parent unit. 2. Remove the batteries in the parent unit. Then, install the batteries again. 3. Wait a few minutes before connecting power back to the baby unit and the parent unit. 4. Turn on the baby unit and the parent unit. 5. Wait for the parent unit to synchronize with the baby unit. Allow up to one minute for this to take place.
Why doesn't the screen of the parent unit go on when I switch on the unit?	Perhaps the rechargeable battery of the parent unit is empty and the parent unit is not connected to the power. Insert the appliance plug into the parent unit and put the adapter in a wall socket.
Why doesn't the POWER light of the baby unit go on when I switch on the unit?	Perhaps the baby unit is not connected to the power. Connect the baby unit to the power.
Why does the baby monitor produce a high-pitched noise?	The units may be too close to each other. Make sure the parent unit and the baby unit are more than 6.5 feet (2 meters) away from each other.
Why does the parent unit react too quickly to other sounds?	The baby unit also detects other sounds than those of your baby. Adjust the VOX sensitivity level to a lower level or adjust the speaker volume on the parent unit.
Why don't I hear a sound/ Why can't I hear my baby cry?	The volume of the parent unit may have set too low. Press to increase the volume level. You may have set a low VOX sensitivity level. See Adjust the sound sensitivity of the baby unit to change the setting.
Why does the parent unit beep?	If the sound alert feature is on, there is sound detected from the baby unit. The baby unit may be out of range. Move the parent unit closer to the baby unit (but not less than 6.5 feet). If the parent unit is powered by the provided battery, it may not have enough charge for the parent unit to perform normally. Charge the battery in the parent unit for up to 11 hours.
Why can't I establish a connection? Why is the connection lost every now and then? Why are there sound interruptions?	The baby unit may be out of range. Move the parent unit closer to the baby unit (but not less than 6.5 feet). Other electronic products may cause interference with your baby monitor. Try installing your baby monitor as far away from these electronic devices as possible.
Why doesn't the battery icon shown on LCD display even I have properly installed the battery?	The battery may not be working. Contact our customer service to purchase a new battery.

IMPORTANT SAFETY INSTRUCTIONS

When using your equipment, basic safety precautions should always be followed to reduce the risk of fire, electric shock and injury, including the following:

1. Follow all warnings and instructions marked on the product.
2. Adult setup is required.
3. This product is not a substitute for adult supervision of the infant. Supervising the infant is the parent's or caregiver's responsibility. This product could cease operating, and therefore you should not assume it will continue working properly for any given period of time. Further, this is not a medical device and should not be used as such. This product is intended to assist you in supervising your baby.
4. Do not use this product near water. For example, do not use it next to a bath tub, wash bowl, kitchen sink, laundry tub or swimming pool, or in a wet basement or shower.
5. **CAUTION:** Use only the batteries indicated in this manual. There may be a risk of explosion if a wrong type of battery is used for the parent unit. Use only the supplied rechargeable battery or replacement battery pack (BT166342/BT266342) for the parent unit. Do not dispose of batteries in a fire. They may explode. Dispose of used battery according to the information in **The RBRC seal**.
6. Use only the adapters included with this product. Incorrect adapter polarity or voltage can seriously damage the product. Baby unit power adapter: Output: 6V DC 400mA; Parent unit power adapter: Output: 6V DC 400mA.
7. The power adapters are intended to be correctly oriented in a vertical or floor mount position. The prongs are not designed to hold the plug in place if it is plugged into a ceiling, under-the-table or cabinet outlet.
8. For pluggable equipment, the socket-outlet shall be installed near the equipment and shall be easily accessible.
9. Unplug this product from the wall outlet before cleaning. Do not use liquid or aerosol cleaners. Use a damp cloth for cleaning.
10. Unplug the power cords before replacing batteries.
11. Do not cut off the power adapters to replace them with other plugs, as this causes a hazardous situation.
12. Do not allow anything to rest on the power cords. Do not install this product where the cords may be walked on or crimped.
13. This product should be operated only from the type of power source indicated on the marking label. If you are not sure of the type of power supply in your home, consult your dealer or local power company.
14. Do not overload wall outlets or use an extension cord.
15. Do not place this product on an unstable table, shelf, stand or other unstable surfaces.
16. This product should not be placed in any area where proper ventilation is not provided. Slots and openings in the back or bottom of this product are provided for ventilation. To protect them from overheating, these openings must not be blocked by placing the product on a soft surface such as a bed, sofa or rug. This product should never be placed near or over a radiator or heat register.
17. Never push objects of any kind into this product through the slots because they may touch dangerous voltage points or create a short circuit. Never spill liquid of any kind on the product.
18. To reduce the risk of electric shock, do not disassemble this product, but take it to an authorized service facility. Opening or removing parts of the product other than specified access doors may expose you to dangerous voltages or other risks. Incorrect reassembling can cause electric shock when the product is subsequently used.
19. You should test the sound reception every time you turn on the units or move one of the components.
20. Periodically examine all components for damage.
21. Be aware of possible loss of privacy while using public airwaves. Conversations may be picked up by other nursery monitors, cordless phones, scanners, etc.
22. Children should be supervised to ensure that they do not play with the product.
23. The product is not intended for use by persons (including children) with reduced physical, sensory or mental capabilities, or lack of experience and knowledge, unless they have been given supervision or instruction concerning use of the appliance by a person responsible for their safety.

SAVE THESE INSTRUCTIONS

Cautions

1. Use and store the product at a temperature between 32°F and 104°F.
2. Do not expose the product to extreme cold, heat or direct sunlight. Do not put the product close to a heating source.
3. Batteries should not be exposed to excessive heat such as bright sunshine or fire.
4.  **Warning**—Strangulation Hazard—Children have STRANGLED in cords. Keep this cord out of the reach of children (more than 3 ft (0.9 m) away). Do not remove this tag.
5. Never place the baby unit inside the baby's crib or playpen. Never cover the baby unit or parent unit with anything such as a towel or a blanket.
6. Other electronic products may cause interference with your baby monitor. Try installing your baby monitor as far away from these electronic devices as possible: wireless routers, radios, cellular telephones, intercoms, room monitors, televisions, personal computers, kitchen appliances and cordless telephones.



Precautions for users of implanted cardiac pacemakers

Cardiac pacemakers (applies only to digital cordless devices):

Wireless Technology Research, LLC (WTR), an independent research entity, led a multidisciplinary evaluation of the interference between portable wireless devices and implanted cardiac pacemakers. Supported by the U.S. Food and Drug Administration, WTR recommends to physicians that:

Pacemaker patients

- Should keep wireless devices at least six inches from the pacemaker.
 - Should NOT place wireless devices directly over the pacemaker, such as in a breast pocket, when it is turned ON.
- WTR's evaluation did not identify any risk to bystanders with pacemakers from other persons using wireless devices.

Electromagnetic fields (EMF)

This VTech product complies with all standards regarding electromagnetic fields (EMF). If handled properly and according to the instructions in this user's manual, the product is safe to be used based on scientific evidence available today.

THE RBRC® SEAL



The RBRC® seal on the nickel-metal battery indicates that VTech Communications, Inc. is voluntarily participating in an industry program to collect and recycle these batteries at the end of their useful lives, when taken out of service within the United States and Canada.

The RBRC® program provides a convenient alternative to placing used nickel-metal batteries into the trash or municipal waste, which may be illegal in your area.

VTech's participation in RBRC® makes it easy for you to drop off the spent battery at local retailers participating in the RBRC® program or at authorized VTech product service centers. Please call

1 (800) 8 BATTERY® for information on Ni-MH battery recycling and disposal bans/restrictions in your area. VTech's involvement in this program is part of its commitment to protecting our environment and conserving natural resources.

RBRC® and 1 (800) 8 BATTERY® are registered trademarks of the Rechargeable Battery Recycling Corporation.

FCC AND IC REGULATIONS

FCC Part 15

This equipment has been tested and found to comply with the requirements for a Class B digital device under Part 15 of the Federal Communications Commission (FCC) rules. These requirements are intended to provide reasonable protection against harmful interference in a residential installation. This equipment generates, uses and can radiate radio frequency energy and, if not installed and used in accordance with the instructions, may cause harmful interference to radio communications. However, there is no guarantee that interference will not occur in a particular installation. If this equipment does cause harmful interference to radio or television reception, which can be determined by turning the equipment off and on, the user is encouraged to try to correct the interference by one or more of the following measures:

- Reorient or relocate the receiving antenna.
- Increase the separation between the equipment and receiver.
- Connect the equipment into an outlet on a circuit different from that to which the receiver is connected.
- Consult the dealer or an experienced radio/TV technician for help.

WARNING: Changes or modifications to this equipment not expressly approved by the party responsible for compliance could void the user's authority to operate the equipment.

This device complies with Part 15 of the FCC rules. Operation is subject to the following two conditions: (1) this device may not cause harmful interference, and (2) this device must accept any interference received, including interference that may cause undesired operation.

To ensure safety of users, the FCC has established criteria for the amount of radio frequency energy that can be safely absorbed by a user or bystander according to the intended usage of the product. This product has been tested and found to comply with the FCC criteria. Caution: This Transmitter must be installed to provide a separation distance of at least 20cm from all persons. The transmitter and antenna of the parent unit shall be held at least 1 in (2.5 cm) from your face.

This Class B digital apparatus complies with Canadian requirement:
CAN ICES-3 (B)/NMB-3(B)

Industry Canada

This device contains licence-exempt transmitter(s)/receiver(s) that comply with Innovation, Science and Economic Development Canada's licence-exempt RSS(s). Operation is subject to the following two conditions: (1) This device may not cause interference. (2) This device must accept any interference, including interference that may cause undesired operation of the device.

The term "IC:" before the certification/registration number only signifies that the Industry Canada technical specifications were met.

This product meets the applicable Innovation, Science and Economic Development Canada technical specifications.

RF radiation exposure statement

The baby unit complies with FCC RF radiation exposure limits set forth for an uncontrolled environment. The baby unit should be installed and operated with a minimum distance of 8 in (20 cm) between the baby unit and all persons' body. For body worn operation, this parent unit has been tested and meets the FCC RF exposure guidelines when used with the accessories supplied or designated for this product. Use of other accessories may not ensure compliance with FCC RF exposure guidelines. This transmitter must not be co-located or operating in conjunction with any other antenna or transmitter. This equipment complies also with Industry Canada RSS-102 with respect to Canada's Health Code 6 for Exposure of Humans to RF Fields.

CALIFORNIA ENERGY COMMISSION BATTERY CHARGING TESTING MODE

This baby monitor meets the California Energy Commission (CEC) regulations for energy consumption. Your baby monitor is set up to comply with the energy-conserving standards right out of the box. Follow the instructions to install and charge the battery. The CEC battery charging testing mode is activated while charging. Even if the parent unit is paired to baby units, the CEC battery charging testing mode is activated while it is powered off and charging.

LIMITED WARRANTY

What does this limited warranty cover?

The manufacturer of this VTech Product warrants to the holder of a valid proof of purchase ("Consumer" or "you") that the Product and all accessories provided in the sales package ("Product") are free from defects in material and workmanship, pursuant to the following terms and conditions, when installed and used normally and in accordance with the Product operating instructions. This limited warranty extends only to the Consumer for Products purchased and used in the United States of America and Canada.

What will VTech do if the Product is not free from defects in materials and workmanship during the limited warranty period ("Materially Defective Product")?

During the limited warranty period, VTech's authorized service representative will repair or replace at VTech's option, without charge, a Materially Defective Product. If we repair the Product, we may use new or refurbished replacement parts. If we choose to replace the Product, we may replace it with a new or refurbished Product of the same or similar design. We will retain defective parts, modules, or equipment. Repair or replacement of the Product, at VTech's option, is your exclusive remedy. VTech will return the repaired or replacement Products to you in working condition. You should expect the repair or replacement to take approximately 30 days.

How long is the limited warranty period?

The limited warranty period for the Product extends for ONE (1) YEAR from the date of purchase. If VTech repairs or replaces a Materially Defective Product under the terms of this limited warranty, this limited warranty also applies to the repaired or replacement Product for a period of either (a) 90 days from the date the repaired or replacement Product is shipped to you or (b) the time remaining on the original one-year warranty; whichever is longer.

What is not covered by this limited warranty?

This limited warranty does not cover:

1. Product that has been subjected to misuse, accident, shipping or other physical damage, improper installation, abnormal operation or handling, neglect, inundation, fire, water or other liquid intrusion; or
2. Product that has been damaged due to repair, alteration or modification by anyone other than an authorized service representative of VTech; or
3. Product to the extent that the problem experienced is caused by signal conditions, network reliability, or cable or antenna systems; or
4. Product to the extent that the problem is caused by use with non-VTech accessories; or
5. Product whose warranty/quality stickers, product serial number plates or electronic serial numbers have been removed, altered or rendered illegible; or
6. Product purchased, used, serviced, or shipped for repair from outside the United States of America or Canada, or used for commercial or institutional purposes (including but not limited to Products used for rental purposes); or
7. Product returned without a valid proof of purchase (see item 2 below); or
8. Charges for installation or set up, adjustment of customer controls, and installation or repair of systems outside the unit.

How do you get warranty service?

To obtain warranty service in the USA, please visit our website at www.vtechphones.com or call 1 (800) 595-9511. In Canada, go to www.vtechcanada.com or call 1 (800) 267-7377.

NOTE: Before calling for service, please review the user's manual - a check of the Product's controls and features may save you a service call.

Except as provided by applicable law, you assume the risk of loss or damage during transit and transportation and are responsible for delivery or handling charges incurred in the transport of the Product(s) to the service location. VTech will return repaired or replaced Product under this limited warranty. Transportation, delivery or handling charges are prepaid. VTech assumes no risk for damage or loss of the Product in transit. If the Product failure is not covered by this limited warranty, or proof of purchase does not meet the terms of this limited warranty, VTech will notify you and will request that you authorize the cost of repair prior to any further repair activity. You must pay for the cost of repair and return shipping costs for the repair of Products that are not covered by this limited warranty.

What must you return with the Product to get warranty service?

1. Return the entire original package and contents including the Product to the VTech service location along with a description of the malfunction or difficulty; and
2. Include a "valid proof of purchase" (sales receipt) identifying the Product purchased (Product model) and the date of purchase or receipt; and
3. Provide your name, complete and correct mailing address, and telephone number.

Other limitations

This warranty is the complete and exclusive agreement between you and VTech. It supersedes all other written or oral communications related to this Product. VTech provides no other warranties for this Product. The warranty exclusively describes all of VTech's responsibilities regarding the Product. There are no other express warranties. No one is authorized to make modifications to this limited warranty and you should not rely on any such modification. State/Provincial Law Rights: This warranty gives you specific legal rights, and you may also have other rights, which vary from state to state or province to province.

Limitations: Implied warranties, including those of fitness for a particular purpose and merchantability (an unwritten warranty that the Product is fit for ordinary use) are limited to one year from the date of purchase. Some states/provinces do not allow limitations on how long an implied warranty lasts, so the above limitation may not apply to you. In no event shall VTech be liable for any indirect, special, incidental, consequential, or similar damages (including, but not limited to lost profits or revenue, inability to use the Product or other associated equipment, the cost of substitute equipment, and claims by third parties) resulting from the use of this Product. Some states/provinces do not allow the exclusion or limitation of incidental or consequential damages, so the above limitation or exclusion may not apply to you.

Please retain your original sales receipt as proof of purchase.