

CAUTION:

To clean use soft, dry cloth. Do not use detergent or chemicals
Avoid contact with water and direct sunlight.
To be assembled on a soft, dry, clean and smooth surface.

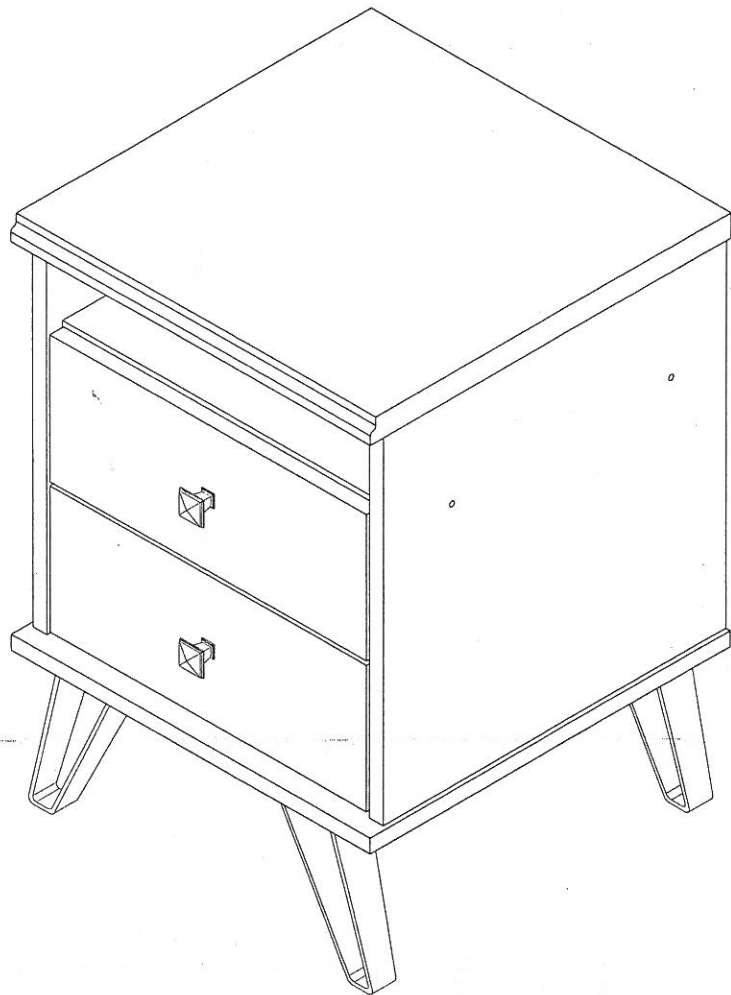

COMPLETE SET

ORDERING REPAIR PARTS

In order to obtain smooth and rapid service when ordering repair parts,
please give full attention to the following of PART NUMBER.

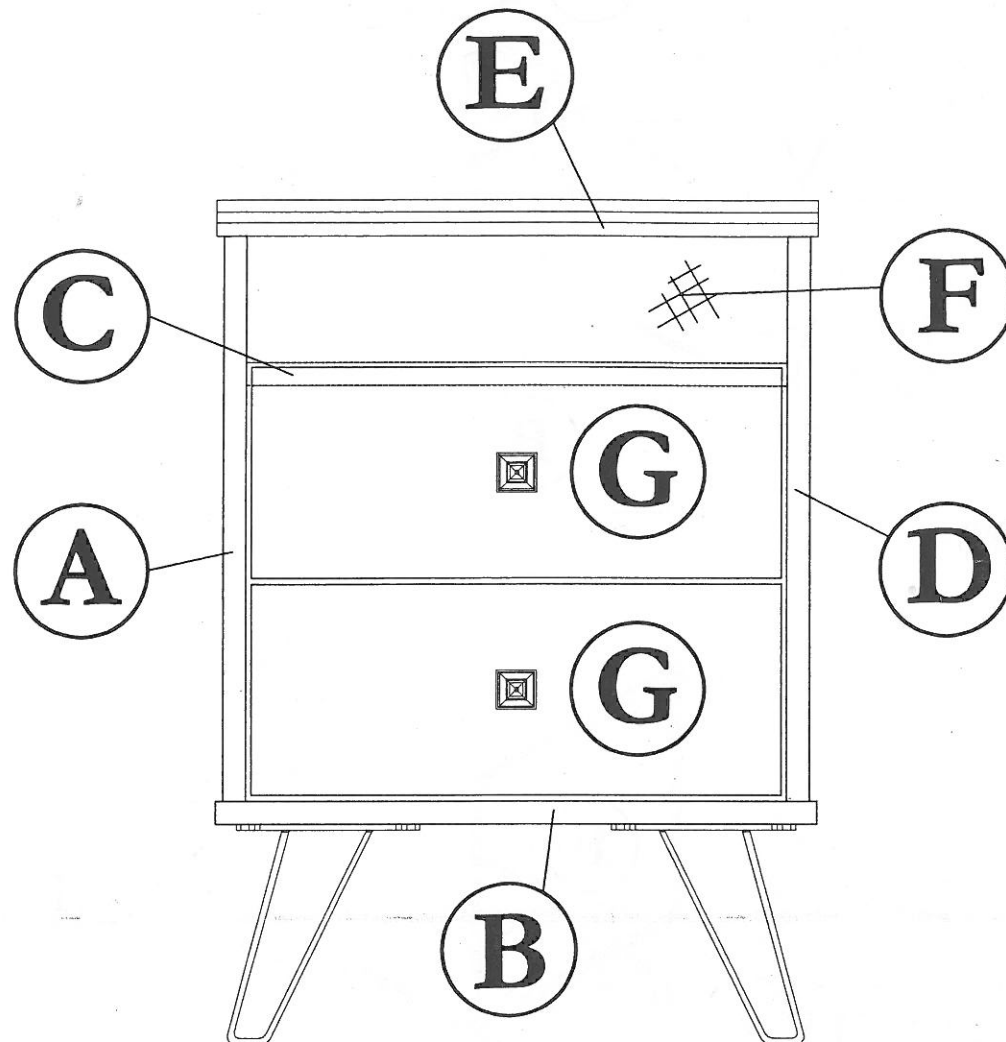

NO	DESCRIPTION	QTY
A	LEFT SIDE	01
B	LOWER SHELF	01
C	CENTRE SHELF	01
D	RIGHT SIDE	01

NO	DESCRIPTION	QTY
E	TOP	01
F	BACK	01
G	DRAWER FACE	02

ASSEMBLY INSTRUCTION
MODEL : 5077 / SIDE TABLE

Before you begin, please follow assembly instruction carefully.
 Then follow them step by step.

STEP 1

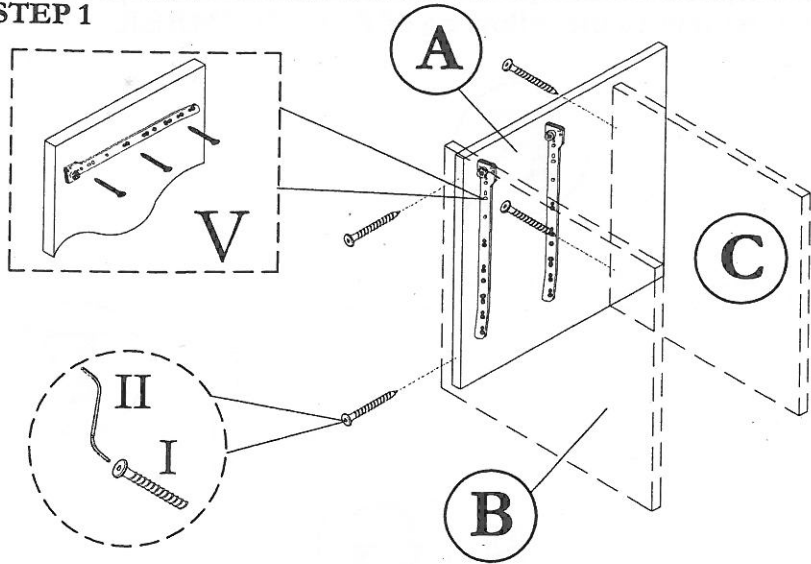

STEP 2

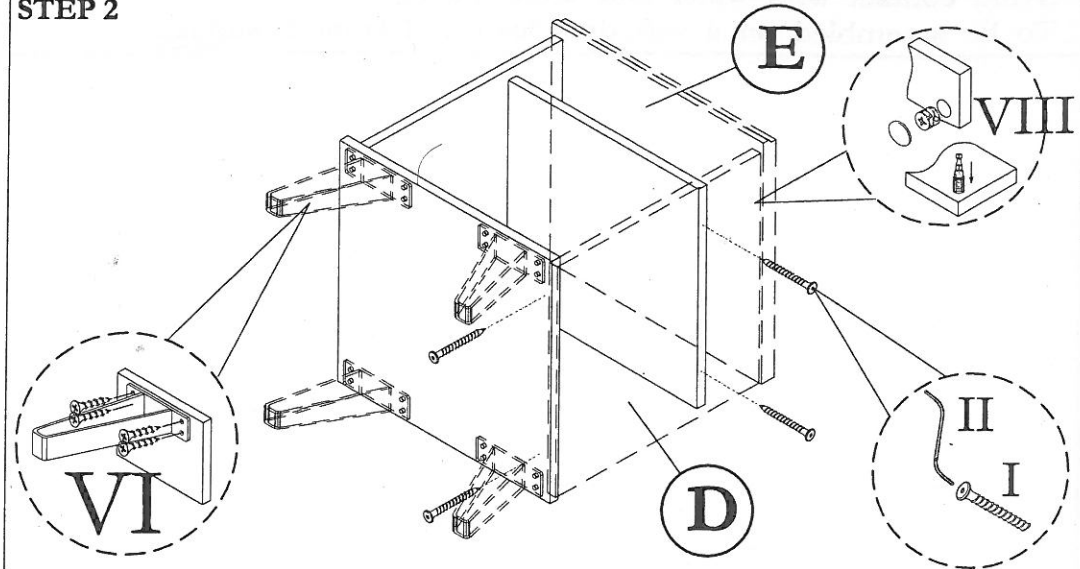

STEP 3

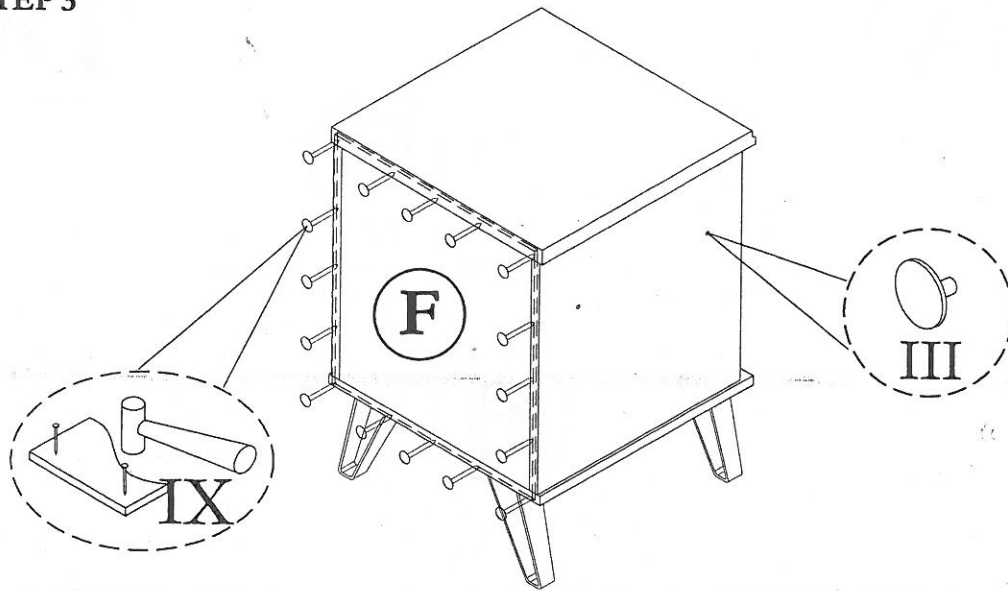

STEP 4

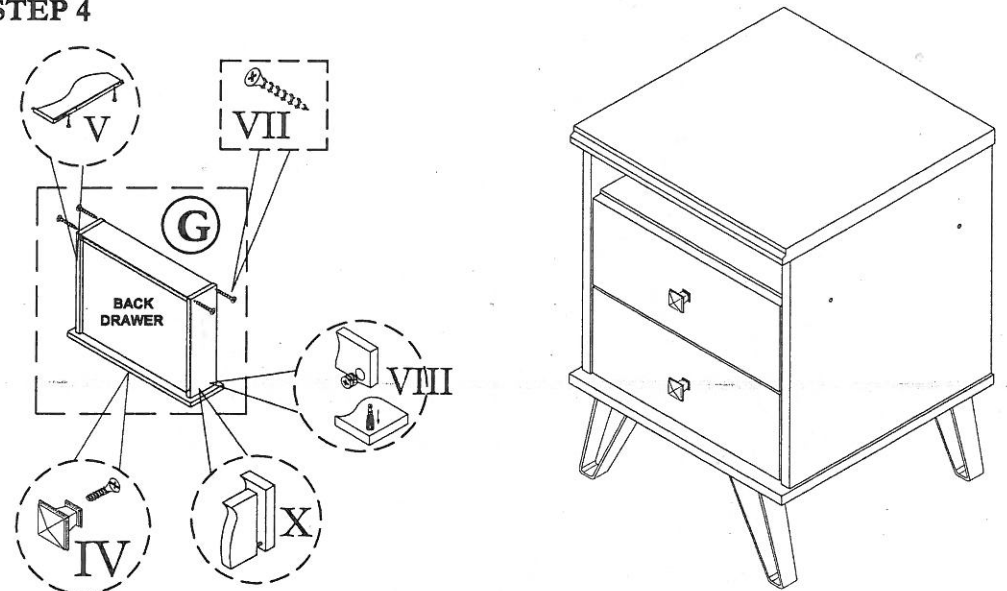

HARDWARE LIST

NO	DESCRIPTION	QTY
I	JCBCW SCREW M6 x 45	8pcs
II	M4 ALLEN KEY	1pc
III	CAP SMALL	4pcs

IV	HANDLE & SCREW M4 x 22	2sets
V	12" DRAWER SLIDER & SCREW M3.5 x 12	2sets
VI	150mm METAL LEG & SCREW M4 x 18	4sets
VII	M8 x 32 CHIPBOARD SCREW	8pcs
VIII	Q-FIT	8sets

IX	NAIL	20pcs
X	PLASTIC DOWEL	4pcs