

CAUTION:

To clean use soft, dry cloth. Do not use detergent or chemicals
Avoid contact with water and direct sunlight.
To be assembled on a soft, dry, clean and smooth surface.

ORDERING REPAIR PARTS

In order to obtain smooth and rapid service when ordering repair parts,
please give full attention to the following of PART NUMBER.

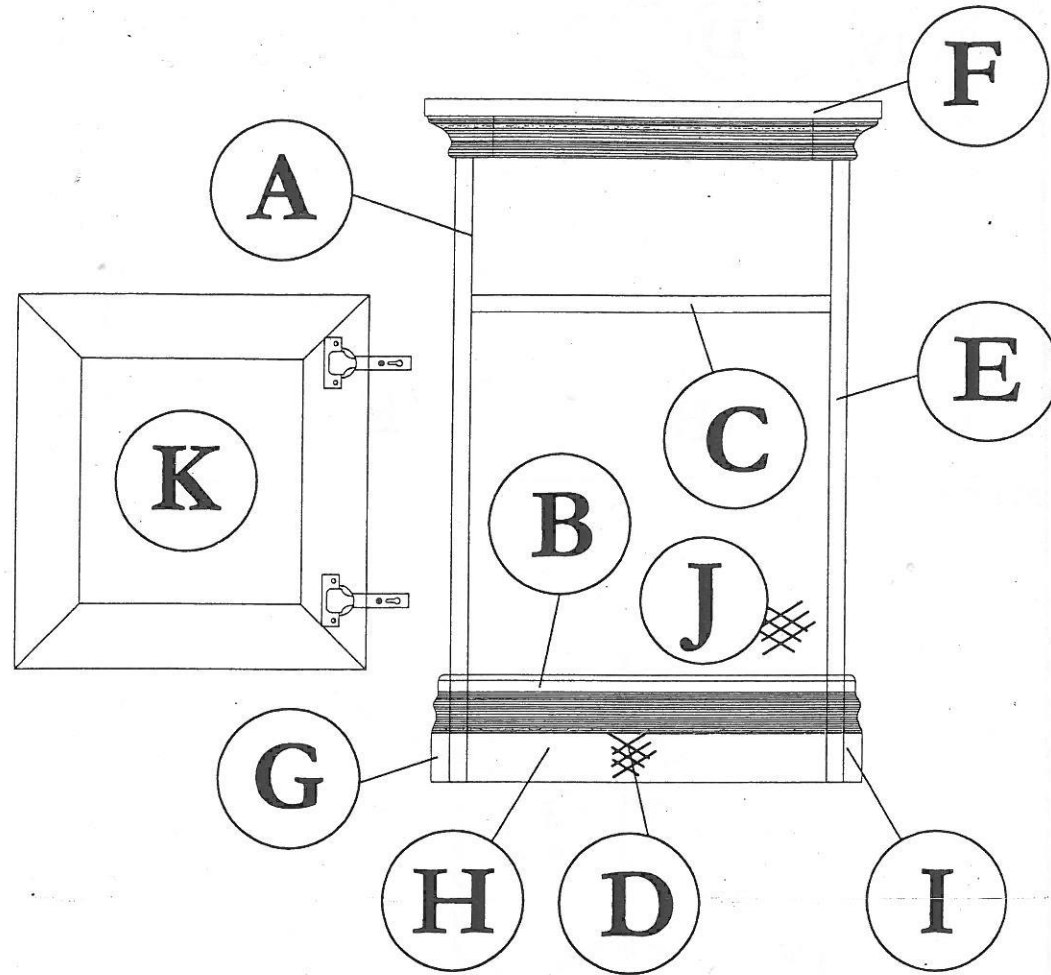
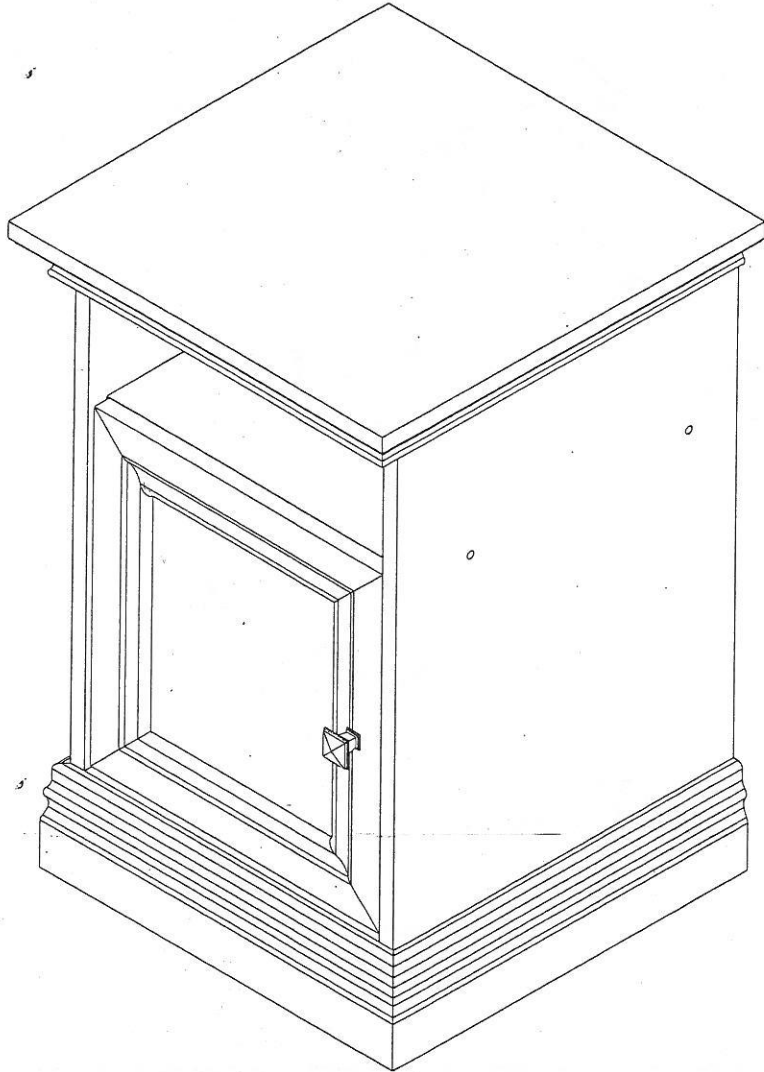

COMPLETE SET

NO	DESCRIPTION	QTY
A	LEFT SIDE	01
B	LOWER SHELF	01
C	CENTRE SHELF	01
D	LEG	01
E	RIGHT SIDE	01
F	TOP	01

NO	DESCRIPTION	QTY
G	LEFT SIDE WRAPPING	01
H	FRONT WRAPPING	01
I	RIGHT SIDE WRAPPING	01
J	BACK	01
K	DOOR	01

ASSEMBLY INSTRUCTION
MODEL : 5081 / SIDE TABLE

Before you begin, please follow assembly instruction carefully.
 Then follow them step by step.

STEP 1

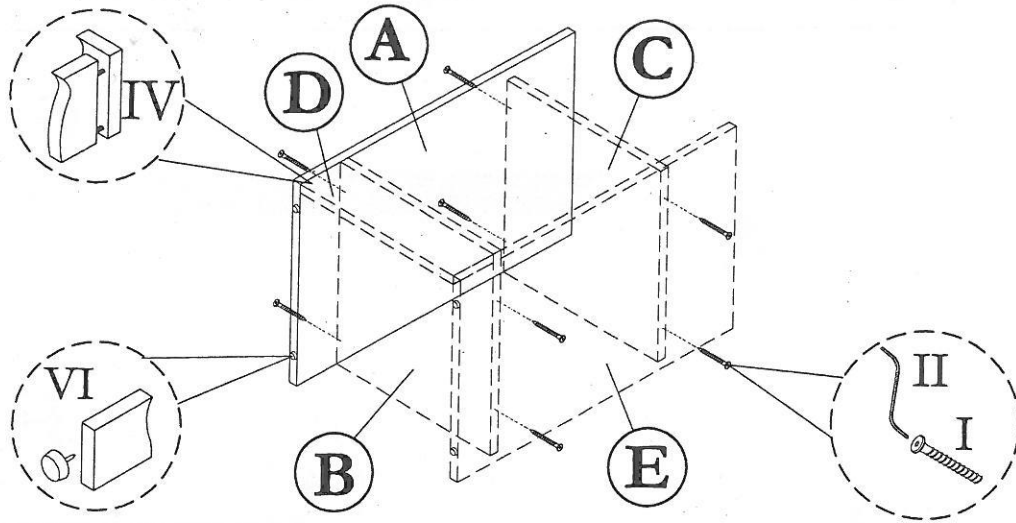

STEP 2

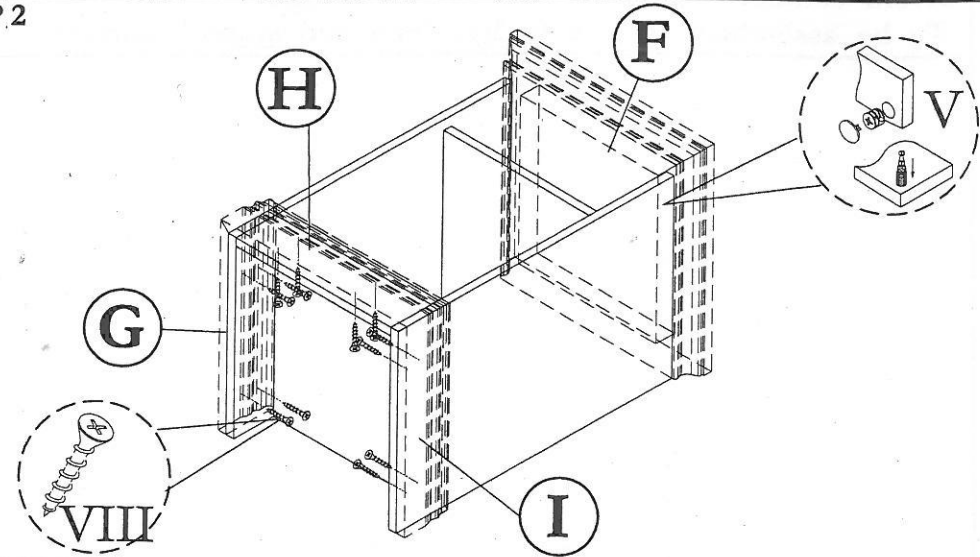

STEP 3

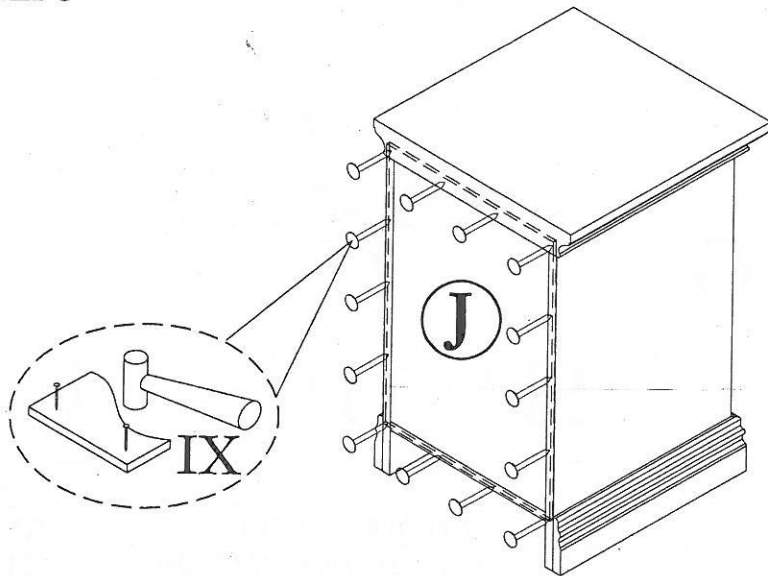

STEP 4

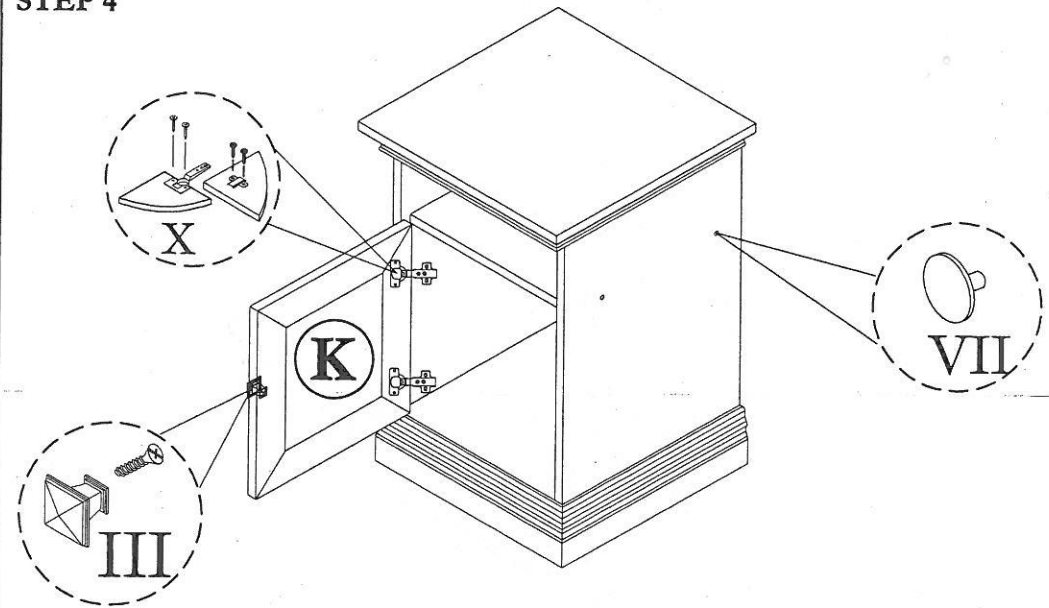

HARDWARE LIST

NO	DESCRIPTION	QTY
I	JCBCW SCREW M6 x 45	8pcs
II	M4 ALLEN KEY	1pc
III	HANDLE & SCREW M4 x 22	1sets

IV	PLASTIC DOWEL	4pcs
V	Q-FIT	4sets
VI	PVC NAIL WITH PIN	4pcs
VII	CAP SMALL	4pcs
VIII	M4 x 25 CHIPBOARD SCREW	12pcs

IX	NAIL	20pcs
X	HINGE (C) & SCREW M3.5 x 16	2sets